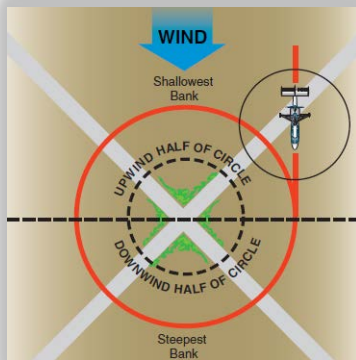




# GYROPLANE FLYING HANDBOOK





# Introduction to the Gyroplane

January 9th, 1923, marked the first officially observed flight of an autogyro. The aircraft, designed by Juan de la Cierva, introduced rotor technology that made forward flight in a rotorcraft possible. Until that time, rotary-wing aircraft designers were stymied by the problem of a rolling moment that was encountered when the aircraft began to move forward. This rolling moment was the product of airflow over the rotor disc, causing an increase in lift of the advancing blade and decrease in lift of the retreating blade. Cierva's successful design, the C.4, introduced the articulated rotor, on which the blades were hinged and allowed to flap. This solution allowed the advancing blade to move upward, decreasing angle of attack and lift, while the retreating blade would swing downward, increasing angle of attack and lift. The result was balanced lift across the rotor disc regardless of airflow. This breakthrough was instrumental in the success of the modern helicopter, which was developed over 15 years later. (For more information on dissymmetry of lift, refer to Chapter 3—Aerodynamics of Flight.) On April 2, 1931, the Pitcairn PCA-2 autogyro was granted Type Certificate No. 410 and became the first rotary wing aircraft to be certified in the United States. The term "autogyro" was used to describe this type of aircraft until the FAA later designated them "gyroplanes."

By definition, the gyroplane is an aircraft that achieves lift by a free spinning rotor. Several aircraft have used the free spinning rotor to attain performance not available in the pure helicopter. The "gyrodyne" is a hybrid rotorcraft that is capable of hovering and yet cruises in

autorotation. The first successful example of this type of aircraft was the British Fairy Rotodyne, certificated to the Transport Category in 1958. During the 1960s and 1970s, the popularity of gyroplanes increased with the certification of the McCulloch J-2 and Umbaugh. The latter becoming the Air & Space 18A.

There are several aircraft under development using the free spinning rotor to achieve rotary wing takeoff performance and fixed wing cruise speeds. The gyroplane offers inherent safety, simplicity of operation, and outstanding short field point-to-point capability.

## TYPES OF GYROPLANES

Because the free spinning rotor does not require an antitorque device, a single rotor is the predominate configuration. Counter-rotating blades do not offer any particular advantage. The rotor system used in a gyroplane may have any number of blades, but the most popular are the two and three blade systems. Propulsion for gyroplanes may be either tractor or pusher, meaning the engine may be mounted on the front and pull the aircraft, or in the rear, pushing it through the air. The powerplant itself may be either reciprocating or turbine. Early gyroplanes were often a derivative of tractor configured airplanes with the rotor either replacing the wing or acting in conjunction with it. However, the pusher configuration is generally more maneuverable due to the placement of the rudder in the propeller slipstream, and also has the advantage of better visibility for the pilot. [Figure 15-1]



Figure 15-1. The gyroplane may have wings, be either tractor or pusher configured, and could be turbine or propeller powered. Pictured are the Pitcairn PCA-2 Autogyro (left) and the Air & Space 18A gyroplane.

When **direct control** of the rotor head was perfected, the jump takeoff gyroplane was developed. Under the proper conditions, these gyroplanes have the ability to lift off vertically and transition to forward flight. Later developments have included retaining the direct control rotor head and utilizing a wing to **unload** the rotor, which results in increased forward speed.

## COMPONENTS

Although gyroplanes are designed in a variety of configurations, for the most part the basic components are the same. The minimum components required for a functional gyroplane are an airframe, a powerplant, a rotor system, tail surfaces, and landing gear. [Figure 15-2] An optional component is the wing, which is incorporated into some designs for specific performance objectives.

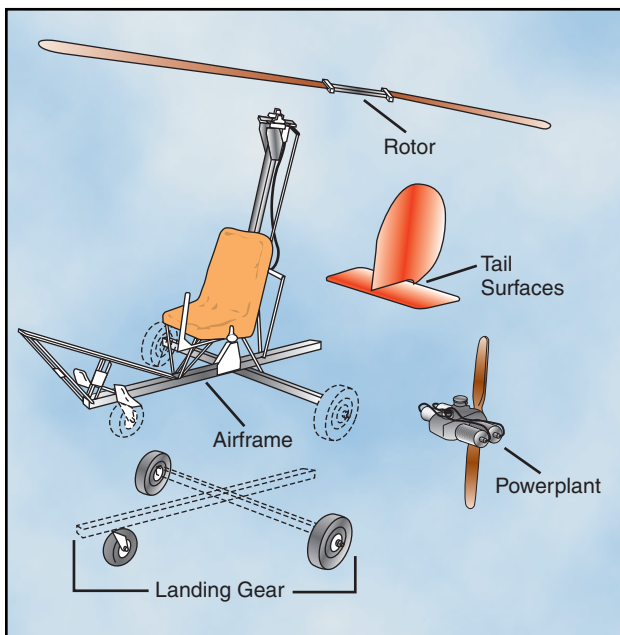


Figure 15-2. Gyroplanes typically consist of five major components. A sixth, the wing, is utilized on some designs.

### AIRFRAME

The airframe provides the structure to which all other components are attached. Airframes may be welded tube, sheet metal, composite, or simply tubes bolted together. A combination of construction methods may also be employed. The airframes with the greatest strength-to-weight ratios are a carbon fiber material or

**Direct Control**—The capacity for the pilot to maneuver the aircraft by tilting the rotor disc and, on some gyroplanes, affect changes in pitch to the rotor blades. These equate to cyclic and collective control, which were not available in earlier autogyros.

**Unload**—To reduce the component of weight supported by the rotor system.

the welded tube structure, which has been in use for a number of years.

### POWERPLANT

The powerplant provides the thrust necessary for forward flight, and is independent of the rotor system while in flight. While on the ground, the engine may be used as a source of power to **prerotate** the rotor system. Over the many years of gyroplane development, a wide variety of engine types have been adapted to the gyroplane. Automotive, marine, ATV, and certificated aircraft engines have all been used in various gyroplane designs. Certificated gyroplanes are required to use FAA certificated engines. The cost of a new certificated aircraft engine is greater than the cost of nearly any other new engine. This added cost is the primary reason other types of engines are selected for use in amateur built gyroplanes.

### ROTOR SYSTEM

The rotor system provides lift and control for the gyroplane. The fully articulated and semi-rigid teetering rotor systems are the most common. These are explained in-depth in Chapter 5—Main Rotor System. The teeter blade with hub tilt control is most common in homebuilt gyroplanes. This system may also employ a collective control to change the pitch of the rotor blades. With sufficient blade inertia and collective pitch change, jump takeoffs can be accomplished.

### TAIL SURFACES

The tail surfaces provide stability and control in the pitch and yaw axes. These tail surfaces are similar to an airplane empennage and may be comprised of a fin and rudder, stabilizer and elevator. An aft mounted duct enclosing the propeller and rudder has also been used. Many gyroplanes do not incorporate a horizontal tail surface.

On some gyroplanes, especially those with an enclosed cockpit, the yaw stability is marginal due to the large fuselage side area located ahead of the center of gravity. The additional vertical tail surface necessary to compensate for this instability is difficult to achieve as the confines of the rotor tilt and high landing pitch attitude limits the available area. Some gyroplane designs incorporate multiple vertical stabilizers and rudders to add additional yaw stability.

**Prerotate**—Spinning a gyroplane rotor to sufficient r.p.m. prior to flight.

## LANDING GEAR

The landing gear provides the mobility while on the ground and may be either conventional or tricycle. Conventional gear consists of two main wheels, and one under the tail. The tricycle configuration also uses two mains, with the third wheel under the nose. Early autogyros, and several models of gyroplanes, use conventional gear, while most of the later gyroplanes incorporate tricycle landing gear. As with fixed wing aircraft, the gyroplane landing gear provides the ground mobility not found in most helicopters.

## WINGS

Wings may or may not comprise a component of the gyroplane. When used, they provide increased performance, increased storage capacity, and increased stability. Gyroplanes are under development with wings that are capable of almost completely unloading the rotor system and carrying the entire weight

of the aircraft. This will allow rotary wing takeoff performance with fixed wing cruise speeds. [Figure 15-3]



**Figure 15-3. The CarterCopter uses wings to enhance performance.**

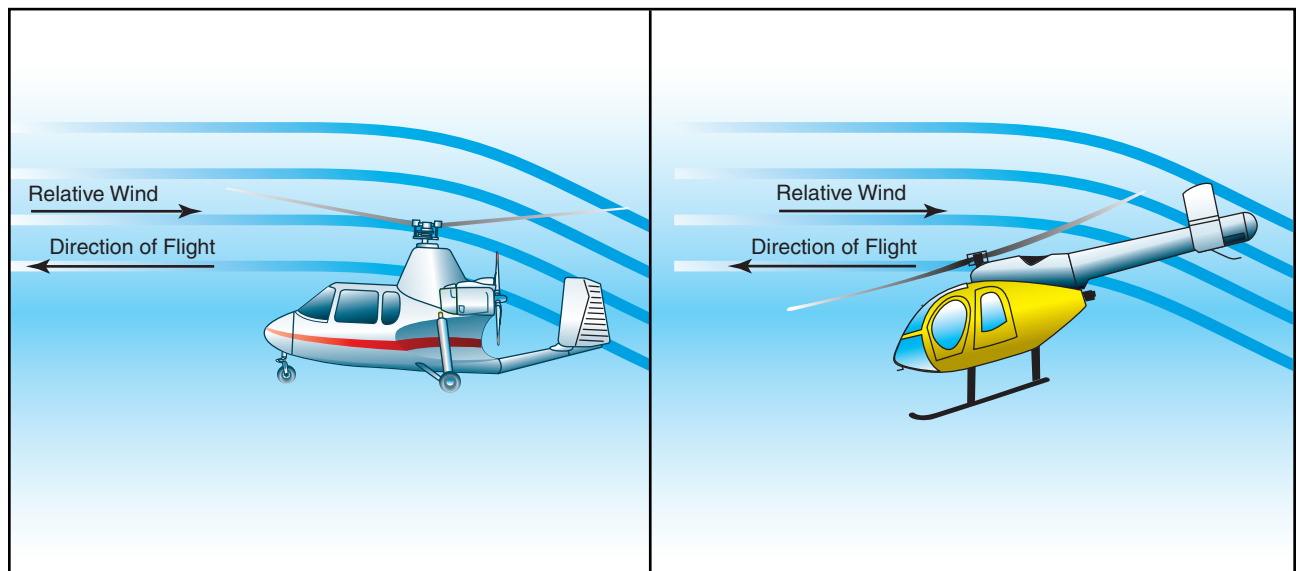


# Aerodynamics of the Gyroplane

Helicopters and gyroplanes both achieve lift through the use of airfoils, and, therefore, many of the basic aerodynamic principles governing the production of lift apply to both aircraft. These concepts are explained in depth in Chapter 2—General Aerodynamics, and constitute the foundation for discussing the aerodynamics of a gyroplane.

## AUTOROTATION

A fundamental difference between helicopters and gyroplanes is that in powered flight, a gyroplane rotor system operates in autorotation. This means the rotor spins freely as a result of air flowing up through the blades, rather than using engine power to turn the blades and draw air from above. [Figure 16-1] Forces are created during autorotation that keep the rotor blades turning, as well as creating lift to keep the aircraft aloft. Aerodynamically, the rotor system of a gyroplane in normal flight operates like a helicopter rotor during an engine-out forward autorotative descent.



**Figure 16-1.** Airflow through the rotor system on a gyroplane is reversed from that on a powered helicopter. This airflow is the medium through which power is transferred from the gyroplane engine to the rotor system to keep it rotating.

## AUTOROTATION IN FORWARD FLIGHT

As discussed thus far, the aerodynamics of autorotation apply to a gyroplane in a vertical descent. Because gyroplanes are normally operated in forward flight, the component of relative wind striking the rotor blades as a result of forward speed must also be considered. This component has no effect on the aerodynamic principles that cause the blades to autorotate, but causes a shift in the zones of the rotor disc.

As a gyroplane moves forward through the air, the forward speed of the aircraft is effectively added to the relative wind striking the advancing blade, and subtracted from the relative wind striking the retreating blade. To prevent uneven lifting forces on the two sides of the rotor disc, the advancing blade teeters up, decreasing angle of attack and lift, while the retreating blade teeters down, increasing angle of attack and lift. (For a complete discussion on dissymmetry of lift, refer to Chapter 3—Aerodynamics of Flight.) The lower angles of attack on the advancing blade cause more of the blade to fall in the driven region, while higher angles of attack on the retreating blade cause more of the blade to be stalled. The result is a shift in the rotor regions toward the retreating side of the disc to a degree directly related to the forward speed of the aircraft. [Figure 16-5]

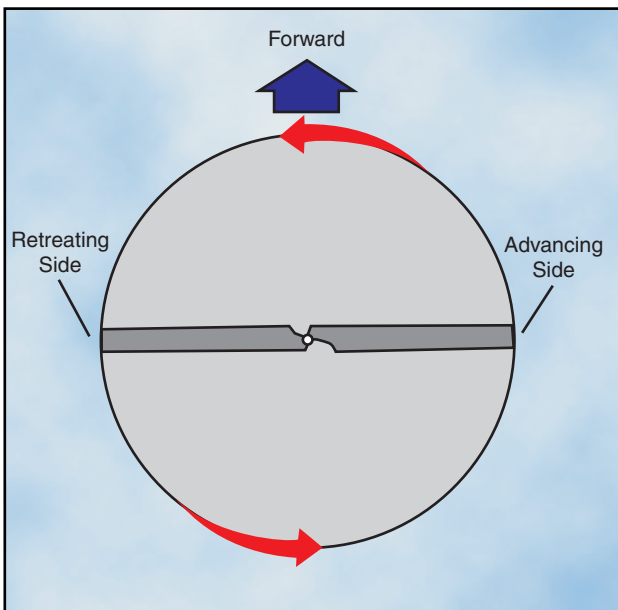


Figure 16-5. Rotor disc in forward autorotative flight.

## DISSYMMETRY OF LIFT

When the helicopter moves through the air, the relative airflow through the main rotor disc is different on the advancing side than on the retreating side. The relative wind encountered by the advancing blade is increased by the forward speed of the helicopter, while the relative wind speed acting on the retreating blade is reduced by the helicopter's forward airspeed. Therefore, as a result of the relative wind speed, the advancing blade side of the rotor disc produces more lift than the retreating blade side. This situation is defined as dissymmetry of lift. [Figure 3-14]

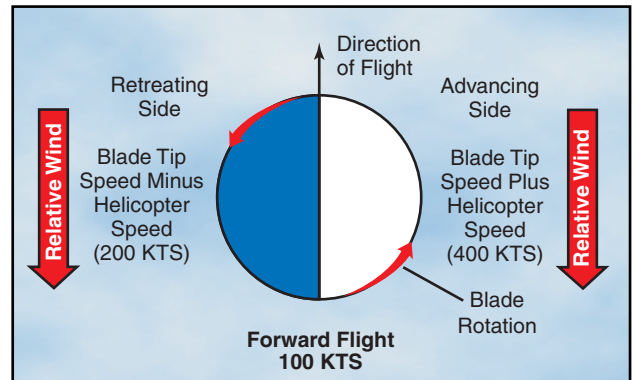


Figure 3-14. The blade tip speed of this helicopter is approximately 300 knots. If the helicopter is moving forward at 100 knots, the relative wind speed on the advancing side is 400 knots. On the retreating side, it is only 200 knots. This difference in speed causes a dissymmetry of lift.

If this condition was allowed to exist, a gyroplane with a counterclockwise main rotor blade rotation would roll to the left because of the difference in lift. In reality, the main rotor blades flap and feather automatically to equalize lift across the rotor disc. Articulated rotor systems, usually with three or more blades, incorporate a horizontal hinge (flapping hinge) to allow the individual rotor blades to move, or flap up and down as they rotate. A semirigid rotor system (two blades) utilizes a teetering hinge, which allows the blades to flap as a unit. When one blade flaps up, the other flaps down.

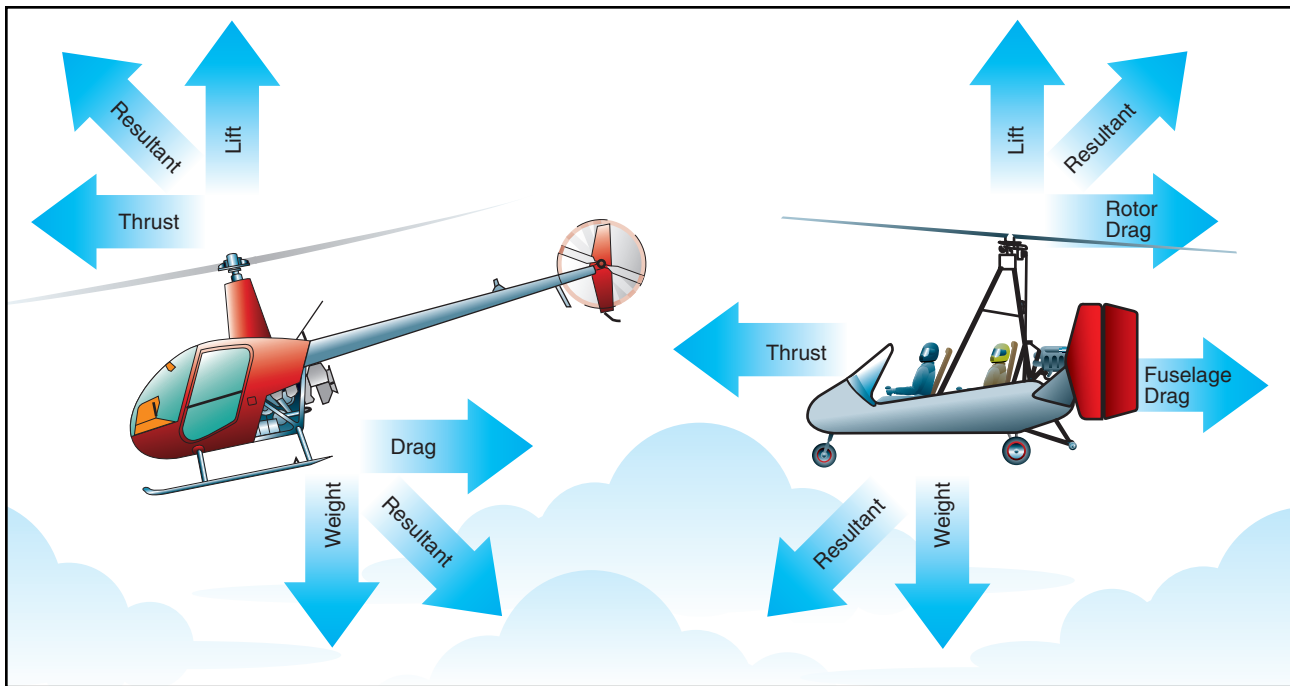


Figure 16-7. Unlike a helicopter, in forward powered flight the resultant rotor force of a gyroplane acts in a rearward direction.

## ROTOR FORCE

As with any heavier than air aircraft, the four forces acting on the gyroplane in flight are lift, weight, thrust and drag. The gyroplane derives lift from the rotor and thrust directly from the engine through a propeller. [Figure 16-7]

The force produced by the gyroplane rotor may be divided into two components; rotor lift and rotor drag. The component of rotor force perpendicular to the flight path is rotor lift, and the component of rotor force parallel to the flight path is rotor drag. To derive the total aircraft drag reaction, you must also add the drag of the fuselage to that of the rotor.

### ROTOR LIFT

Rotor lift can most easily be visualized as the lift required to support the weight of the aircraft. When an airfoil produces lift, induced drag is produced. The most efficient angle of attack for a given airfoil produces the most lift for the least drag. However, the airfoil of a rotor blade does not operate at this efficient angle throughout the many changes that occur in each revolution. Also, the rotor system must remain in the autorotative (low) pitch range to continue turning in order to generate lift.

### ROTOR DRAG

Total rotor drag is the summation of all the drag forces acting on the airfoil at each blade position. Each blade position contributes to the total drag according to the speed and angle of the airfoil at that position. As the

rotor blades turn, rapid changes occur on the airfoils depending on position, rotor speed, and aircraft speed. A change in the angle of attack of the rotor disc can effect a rapid and substantial change in total rotor drag.

Rotor drag can be divided into components of induced drag and profile drag. The induced drag is a product of lift, while the profile drag is a function of rotor r.p.m. Because induced drag is a result of the rotor providing lift, profile drag can be considered the drag of the rotor when it is not producing lift. To visualize profile drag, consider the drag that must be overcome to prerotate the rotor system to flight r.p.m. while the blades are producing no lift. This can be achieved with a rotor system having a symmetrical airfoil and a pitch change capability by setting the blades to a  $0^\circ$  angle of attack. A rotor system with an asymmetrical airfoil and a built in pitch angle, which includes most amateur-built teeter-head rotor systems, cannot be prerotated without having to overcome the induced drag created as well.

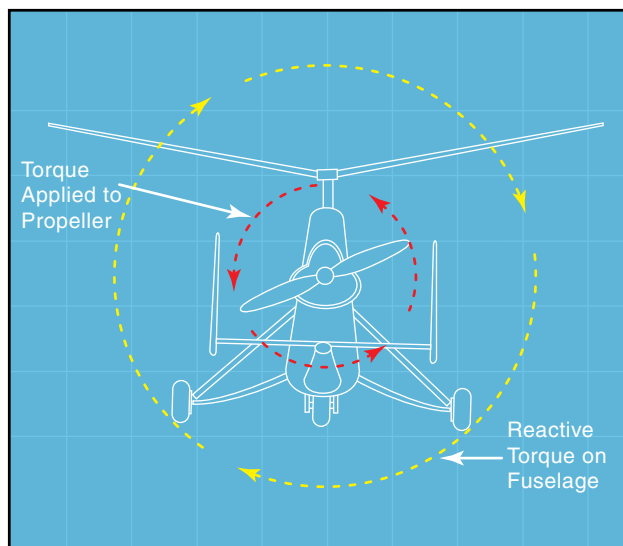
## THRUST

Thrust in a gyroplane is defined as the component of total propeller force parallel to the relative wind. As with any force applied to an aircraft, thrust acts around the center of gravity. Based upon where the thrust is applied in relation to the aircraft center of gravity, a relatively small component may be perpendicular to the relative wind and can be considered to be additive to lift or weight.

In flight, the fuselage of a gyroplane essentially acts as a plumb suspended from the rotor, and as such, it is



subject to **pendular action** in the same way as a helicopter. Unlike a helicopter, however, thrust is applied directly to the airframe of a gyroplane rather than being obtained through the rotor system. As a result, different forces act on a gyroplane in flight than on a helicopter. Engine torque, for example, tends to roll the fuselage in the direction opposite propeller rotation, causing it to be deflected a few degrees out of the vertical plane. [Figure 16-8] This slight “out of vertical” condition is usually negligible and not considered relevant for most flight operations.



**Figure 16-8. Engine torque applied to the propeller has an equal and opposite reaction on the fuselage, deflecting it a few degrees out of the vertical plane in flight.**

## STABILITY

Stability is designed into aircraft to reduce pilot workload and increase safety. A stable aircraft, such as a typical general aviation training airplane, requires less attention from the pilot to maintain the desired flight attitude, and will even correct itself if disturbed by a gust of wind or other outside forces. Conversely, an unstable aircraft requires constant attention to maintain control of the aircraft.

**Pendular Action**—The lateral or longitudinal oscillation of the fuselage due to it being suspended from the rotor system. It is similar to the action of a pendulum. Pendular action is further discussed in Chapter 3—Aerodynamics of Flight.

There are several factors that contribute to the stability of a gyroplane. One is the location of the horizontal stabilizer. Another is the location of the fuselage drag in relation to the center of gravity. A third is the inertia moment around the pitch axis, while a fourth is the relation of the propeller thrust line to the vertical location of the center of gravity (CG). However, the one that is probably the most critical is the relation of the rotor force line to the horizontal location of the center of gravity.

## HORIZONTAL STABILIZER

A horizontal stabilizer helps in longitudinal stability, with its efficiency greater the further it is from the center of gravity. It is also more efficient at higher airspeeds because lift is proportional to the square of the airspeed. Since the speed of a gyroplane is not very high, manufacturers can achieve the desired stability by varying the size of the horizontal stabilizer, changing the distance it is from the center of gravity, or by placing it in the propeller slipstream.

## FUSELAGE DRAG (CENTER OF PRESSURE)

If the location, where the fuselage drag or center of pressure forces are concentrated, is behind the CG, the gyroplane is considered more stable. This is especially true of yaw stability around the vertical axis. However, to achieve this condition, there must be a sufficient vertical tail surface. In addition, the gyroplane needs to have a balanced longitudinal center of pressure so there is sufficient cyclic movement to prevent the nose from tucking under or lifting, as pressure builds on the frontal area of the gyroplane as airspeed increases.

## PITCH INERTIA

Without changing the overall weight and center of gravity of a gyroplane, the further weights are placed from the CG, the more stable the gyroplane. For example, if the pilot's seat could be moved forward from the CG, and the engine moved aft an amount, which keeps the center of gravity in the same location, the gyroplane becomes more stable. A tightrope walker applies this same principle when he uses a long pole to balance himself.

## PROPELLER THRUST LINE

Considering just the propeller thrust line by itself, if the thrust line is above the center of gravity, the gyroplane has a tendency to pitch nose down when power is applied, and to pitch nose up when power is removed. The opposite is true when the propeller thrust line is below the CG. If the thrust line goes through the CG or

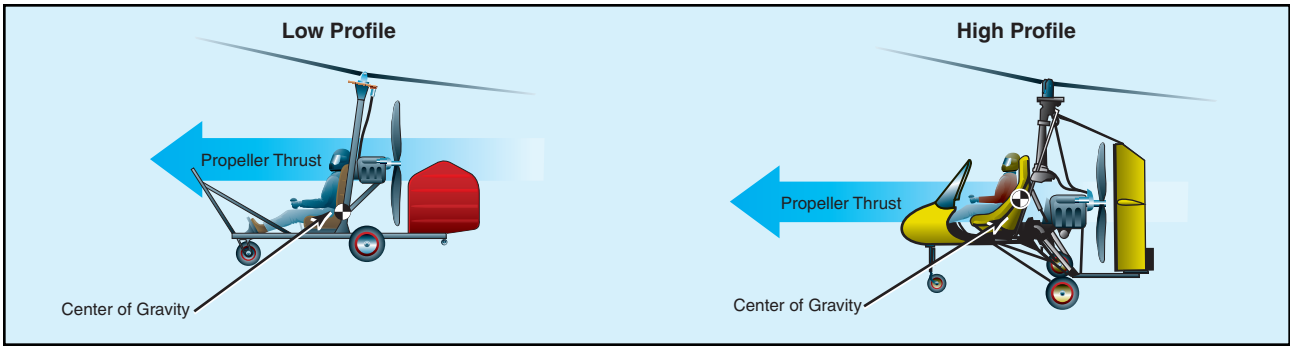


Figure 16-9. A gyroplane which has the propeller thrust line above the center of gravity is often referred to as a low profile gyroplane. One that has the propeller thrust line below or at the CG is considered a high profile gyroplane.

nearly so there is no tendency for the nose to pitch up or down. [Figure 16-9]

### ROTOR FORCE

Because some gyroplanes do not have horizontal stabilizers, and the propeller thrust lines are different, gyroplane manufacturers can achieve the desired stability by placing the center of gravity in front of or behind the rotor force line. [Figure 16-10]

Suppose the CG is located behind the rotor force line in forward flight. If a gust of wind increases the angle of attack, rotor force increases. There is also an increase in the difference between the lift produced on the advancing and retreating blades. This increases the flapping angle and causes the rotor to pitch up. This pitching action increases the moment around the center of gravity, which leads to a greater increase in the angle of attack. The result is an unstable condition.

If the CG is in front of the rotor force line, a gust of wind, which increases the angle of attack, causes the rotor disc to react the same way, but now the increase in rotor force and **blade flapping** decreases the moment. This tends to decrease the angle of attack, and creates a stable condition.

### TRIMMED CONDITION

As was stated earlier, manufacturers use a combination of the various stability factors to achieve a trimmed gyroplane. For example, if you have a gyroplane where the CG is below the propeller thrust line, the propeller thrust gives your aircraft a nose down pitching moment when power is applied. To compensate for this pitching moment, the CG, on this type of gyroplane, is usually located behind the rotor force line. This location produces a nose up pitching moment.

Conversely, if the CG is above the propeller thrust line, the CG is usually located ahead of the rotor force line. Of course, the location of fuselage drag, the pitch inertia, and the addition of a horizontal stabilizer can alter where the center of gravity is placed.

**Blade Flapping**—The upward or downward movement of the rotor-blades during rotation.

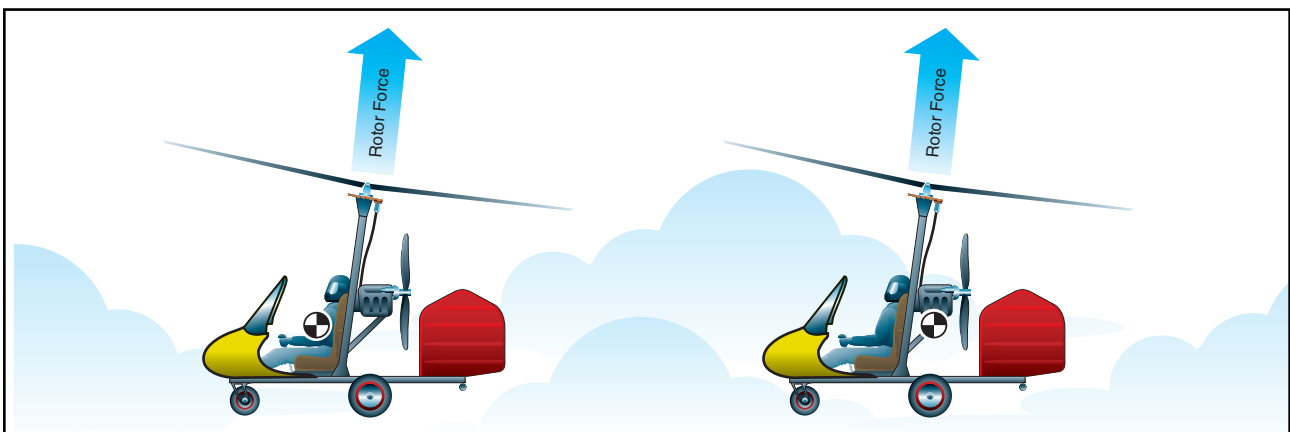


Figure 16-10. If the CG is located in front of the rotor force line, the gyroplane is more stable than if the CG is located behind the rotor force line.

# Gyroplane Flight Controls

Due to rudimentary flight control systems, early gyroplanes suffered from limited maneuverability. As technology improved, greater control of the rotor system and more effective control surfaces were developed. The modern gyroplane, while continuing to maintain an element of simplicity, now enjoys a high degree of maneuverability as a result of these improvements.

## CYCLIC CONTROL

The cyclic control provides the means whereby you are able to tilt the rotor system to provide the desired results. Tilting the rotor system provides all control for climbing, descending, and banking the gyroplane. The most common method to transfer stick movement to the rotor head is through push-pull tubes or flex cables. [Figure 17-1] Some gyroplanes use a direct overhead stick attachment rather than a cyclic, where a rigid control is attached to the rotor hub and descends over and in front of the pilot. [Figure 17-2] Because of the nature of the direct attachment, control inputs with this system are reversed from those used with a cyclic. Pushing forward on the control causes the rotor disc to tilt back and the gyroplane to climb, pulling back on the control initiates a descent. Bank commands are reversed in the same way.

## THROTTLE

The throttle is conventional to most powerplants, and provides the means for you to increase or decrease engine power and thus, thrust. Depending on how

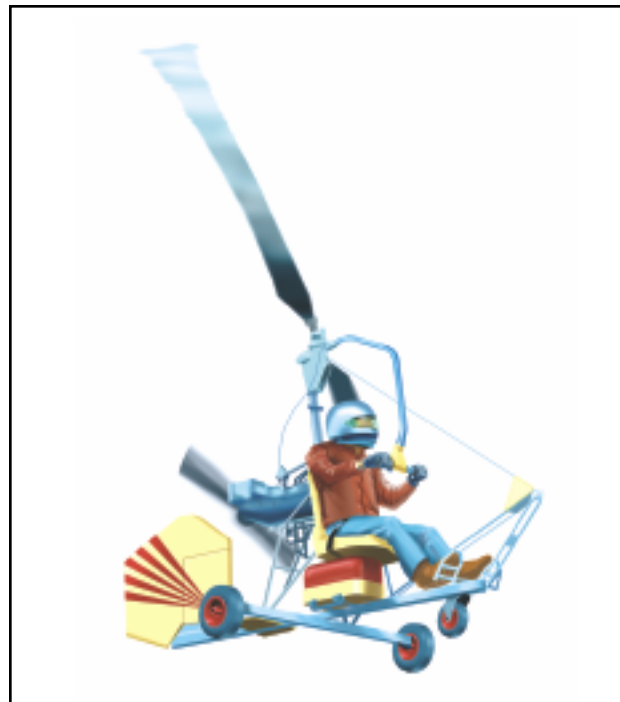


Figure 17-2. The direct overhead stick attachment has been used for control of the rotor disc on some gyroplanes.

the control is designed, control movement may or may not be proportional to engine power. With many gyroplane throttles, 50 percent of the control travel may equate to 80 or 90 percent of available power. This varying degree of sensitivity makes it necessary

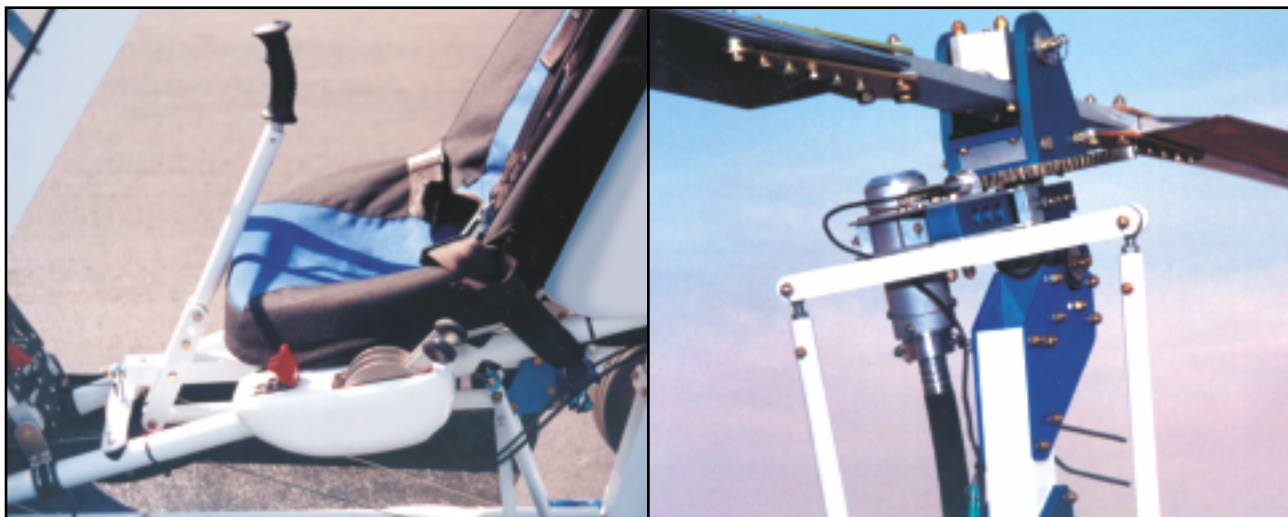


Figure 17-1. A common method of transferring cyclic control inputs to the rotor head is through the use of push-pull tubes, located outboard of the rotor mast pictured on the right.



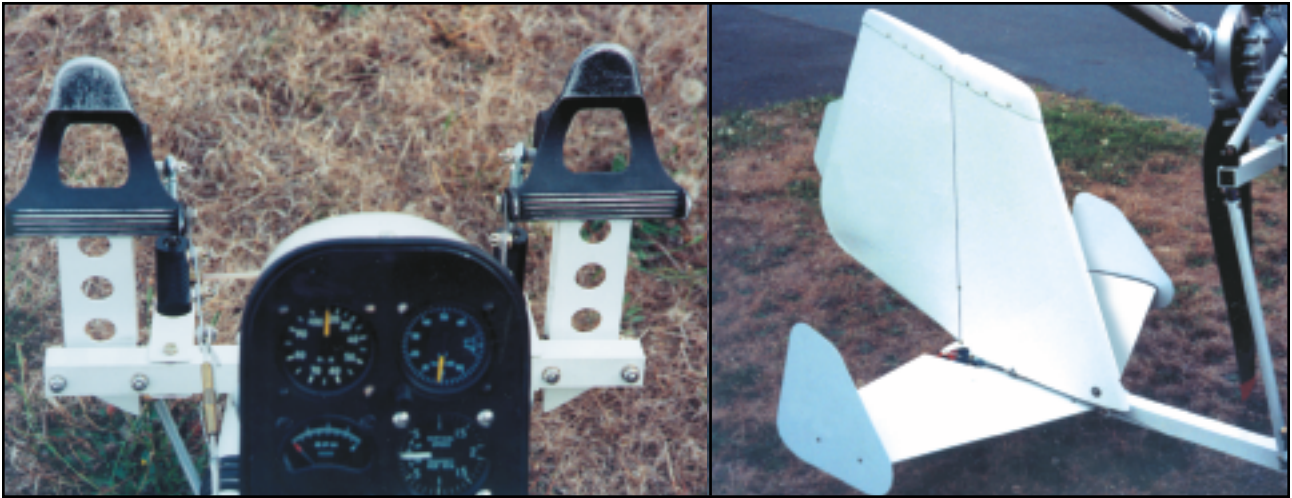


Figure 17-3. Foot pedals provide rudder control and operation is similar to that of an airplane.

for you to become familiar with the unique throttle characteristics and engine responses for a particular gyroplane.

## RUDDER

The rudder is operated by foot pedals in the cockpit and provides a means to control yaw movement of the aircraft. [Figure 17-3] On a gyroplane, this control is achieved in a manner more similar to the rudder of an airplane than to the antitorque pedals of a helicopter. The rudder is used to maintain coordinated flight, and at times may also require inputs to compensate for propeller torque. Rudder sensitivity and effectiveness are directly proportional to the velocity of airflow over the rudder surface. Consequently, many gyroplane rudders are located in the propeller slipstream and provide excellent control while the engine is developing thrust. This type of rudder configuration, however, is less effective and requires greater deflection when the engine is idled or stopped.

## HORIZONTAL TAIL SURFACES

The horizontal tail surfaces on most gyroplanes are not controllable by the pilot. These fixed surfaces, or

stabilizers, are incorporated into gyroplane designs to increase the pitch stability of the aircraft. Some gyroplanes use very little, if any, horizontal surface. This translates into less stability, but a higher degree of maneuverability. When used, a moveable horizontal surface, or elevator, adds additional pitch control of the aircraft. On early tractor configured gyroplanes, the elevator served an additional function of deflecting the propeller slipstream up and through the rotor to assist in prerotation.

## COLLECTIVE CONTROL

The collective control provides a means to vary the rotor blade pitch of all the blades at the same time, and is available only on more advanced gyroplanes. When incorporated into the rotor head design, the collective allows jump takeoffs when the blade inertia is sufficient. Also, control of in-flight rotor r.p.m. is available to enhance cruise and landing performance. A simple two position collective does not allow unlimited control of blade pitch, but instead has one position for prerotation and another position for flight. This is a performance compromise but reduces pilot workload by simplifying control of the rotor system.

# Gyroplane Systems

Gyroplanes are available in a wide variety of designs that range from amateur built to FAA-certificated aircraft. Similarly, the complexity of the systems integrated in gyroplane design cover a broad range. To ensure the airworthiness of your aircraft, it is important that you thoroughly understand the design and operation of each system employed by your machine.

## PROPULSION SYSTEMS

Most of the gyroplanes flying today use a reciprocating engine mounted in a pusher configuration that drives either a fixed or constant speed propeller. The engines used in amateur-built gyroplanes are normally proven powerplants adapted from automotive or other uses. Some amateur-built gyroplanes use FAA-certificated aircraft engines and propellers. Auto engines, along with some of the other powerplants adapted to gyroplanes, operate at a high r.p.m., which requires the use of a reduction unit to lower the output to efficient propeller speeds.

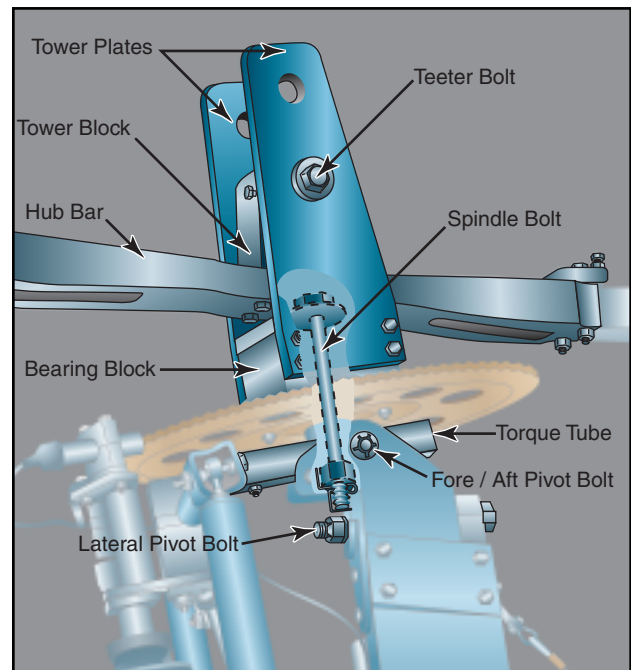
Early autogyros used existing aircraft engines, which drove a propeller in the tractor configuration. Several amateur-built gyroplanes still use this propulsion configuration, and may utilize a certificated or an uncertificated engine. Although not in use today, turboprop and pure jet engines could also be used for the propulsion of a gyroplane.

## ROTOR SYSTEMS

### SEMIRIGID ROTOR SYSTEM

Any rotor system capable of autorotation may be utilized in a gyroplane. Because of its simplicity, the most widely used system is the semirigid, teeter-head system. This system is found in most amateur-built gyroplanes. [Figure 18-1] In this system, the rotor head is mounted on a spindle, which may be tilted for control. The rotor blades are attached to a hub bar that may or may not have adjustments for varying the blade pitch. A **coning angle**, determined by projections of blade weight, rotor speed, and load to be carried, is built into the hub bar. This minimizes hub bar bending moments and eliminates the need for a coning hinge, which is used in more complex rotor systems. A tower block provides the **undersling** and attachment to the rotor head by the teeter bolt. The rotor head is comprised of a bearing block in which the bearing is mounted and onto which the tower plates are attached. The spindle (commonly, a vertically oriented bolt) attaches the

rotating portion of the head to the non-rotating torque tube. The torque tube is mounted to the airframe through attachments allowing both lateral and longitudinal movement. This allows the movement through which control is achieved.



**Figure 18-1.** The semirigid, teeter-head system is found on most amateur-built gyroplanes. The rotor hub bar and blades are permitted to tilt by the teeter bolt.

### FULLY ARTICULATED ROTOR SYSTEM

The fully articulated rotor system is found on some gyroplanes. As with helicopter-type rotor systems, the articulated rotor system allows the manipulation of

**Coning Angle**—An angular deflection of the rotor blades upward from the rotor hub.

**Undersling**—A design characteristic that prevents the distance between the rotor mast axis and the center of mass of each rotor blade from changing as the blades teeter. This precludes Coriolis Effect from acting on the speed of the rotor system. Undersling is further explained in Chapter 3—Aerodynamics of Flight, Coriolis Effect (Law of Conservation of Angular Momentum).

rotor blade pitch while in flight. This system is significantly more complicated than the teeter-head, as it requires hinges that allow each rotor blade to flap, feather, and lead or lag independently. [Figure 18-2] When used, the fully articulated rotor system of a gyroplane is very similar to those used on helicopters, which is explained in depth in Chapter 5—Helicopter Systems, Main Rotor Systems. One major advantage of using a fully articulated rotor in gyroplane design is that it usually allows jump takeoff capability. Rotor characteristics required for a successful jump takeoff must include a method of collective pitch change, a blade with sufficient inertia, and a prerotation mechanism capable of approximately 150 percent of rotor flight r.p.m.



**Figure 18-2.** The fully articulated rotor system enables the pilot to effect changes in pitch to the rotor blades, which is necessary for jump takeoff capability.

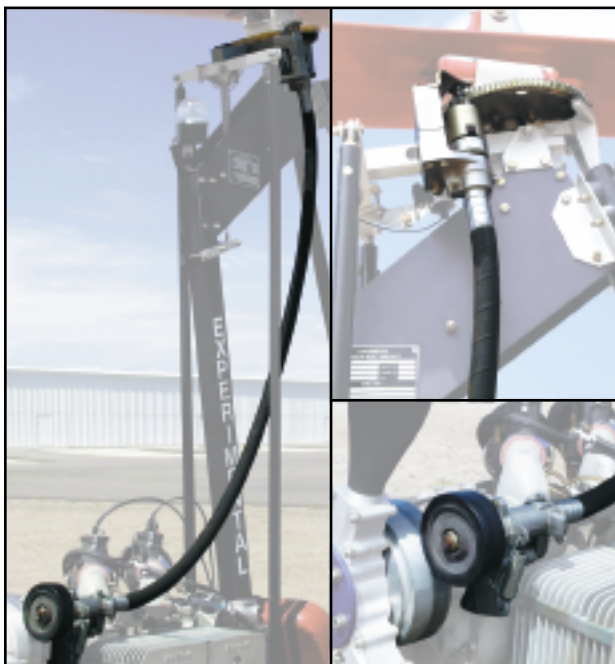
Incorporating rotor blades with high inertia potential is desirable in helicopter design and is essential for jump takeoff gyroplanes. A rotor hub design allowing the rotor speed to exceed normal flight r.p.m. by over 50 percent is not found in helicopters, and predates a rotor head design particular to the jump takeoff gyroplane, yet very similar to that of the helicopter.

## PREROTATOR

Prior to takeoff, the gyroplane rotor must first achieve a rotor speed sufficient to create the necessary lift. This is accomplished on very basic gyroplanes by initially spinning the blades by hand. The aircraft is then taxied with the rotor disc tilted aft, allowing airflow through the system to accelerate it to flight r.p.m. More advanced gyroplanes use a prerotator, which provides a mechanical means to spin the rotor. Many prerotators are capable of only achieving a portion of the speed necessary for flight; the remainder is gained by taxiing or during the takeoff roll. Because of the wide variety of prerotation systems available, you need to become thoroughly familiar with the characteristics and techniques associated with your particular system.

## MECHANICAL PREROTATOR

Mechanical prerotators typically have clutches or belts for engagement, a drive train, and may use a transmission to transfer engine power to the rotor. Friction drives and flex cables are used in conjunction with an automotive type bendix and ring gear on many gyroplanes. [Figure 18-3]



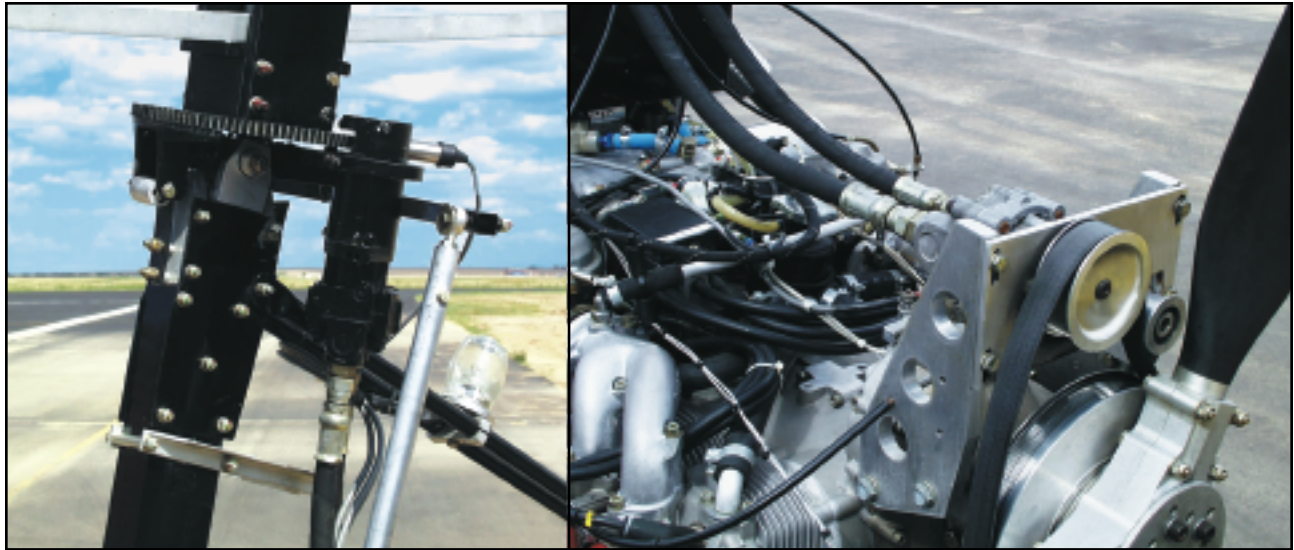
**Figure 18-3.** The mechanical prerotator used by many gyroplanes uses a friction drive at the propeller hub, and a flexible cable that runs from the propeller hub to the rotor mast. When engaged, the bendix spins the ring gear located on the rotor hub.

The mechanical prerotator used on jump takeoff gyroplanes may be regarded as being similar to the helicopter main rotor drive train, but only operates while the aircraft is firmly on the ground. Gyroplanes do not have an antitorque device like a helicopter, and ground contact is necessary to counteract the torque forces generated by the prerotation system. If jump takeoff capability is designed into a gyroplane, rotor r.p.m. prior to liftoff must be such that rotor energy will support the aircraft through the acceleration phase of takeoff. This combination of rotor system and prerotator utilizes the transmission only while the aircraft is on the ground, allowing the transmission to be disconnected from both the rotor and the engine while in normal flight.

## HYDRAULIC PREROTATOR

The hydraulic prerotator found on gyroplanes uses engine power to drive a hydraulic pump, which in turn drives a hydraulic motor attached to an automotive type bendix and ring gear. [Figure 18-4] This system also requires that some type of clutch and pressure regulation be incorporated into the design.

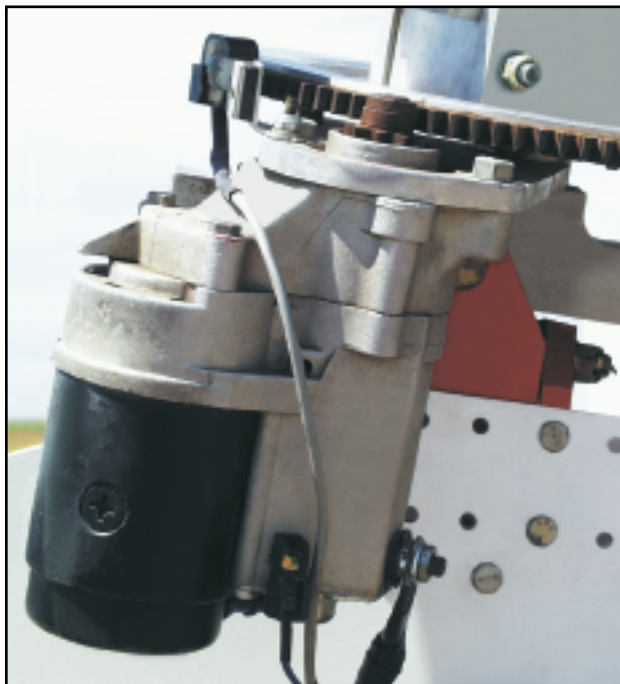




**Figure 18-4.** This prerotator uses belts at the propeller hub to drive a hydraulic pump, which drives a hydraulic motor on the rotor mast.

### **ELECTRIC PREROTATOR**

The electric prerotator found on gyroplanes uses an automotive type starter with a bendix and ring gear mounted at the rotor head to impart torque to the rotor system. [Figure 18-5] This system has the advantage of simplicity and ease of operation, but is dependent on having electrical power available. Using a “soft start” device can alleviate the problems associated with the high starting torque initially required to get the rotor system turning. This device delivers electrical pulses to the starter for approximately 10 seconds before connecting uninterrupted voltage.



**Figure 18-5.** The electric prerotator is simple and easy to use, but requires the availability of electrical power.

### **TIP JETS**

Jets located at the rotor blade tips have been used in several applications for prerotation, as well as for hover flight. This system has no requirement for a transmission or clutches. It also has the advantage of not imparting torque to the airframe, allowing the rotor to be powered in flight to give increased climb rates and even the ability to hover. The major disadvantage is the noise generated by the jets. Fortunately, tip jets may be shut down while operating in the autorotative gyroplane mode.

### **INSTRUMENTATION**

The instrumentation required for flight is generally related to the complexity of the gyroplane. Some gyroplanes using air-cooled and fuel/oil-lubricated engines may have limited instrumentation.

### **ENGINE INSTRUMENTS**

All but the most basic engines require monitoring instrumentation for safe operation. Coolant temperature, cylinder head temperatures, oil temperature, oil pressure, carburetor air temperature, and exhaust gas temperature are all direct indications of engine operation and may be displayed. Engine power is normally indicated by engine r.p.m., or by manifold pressure on gyroplanes with a constant speed propeller.

### **ROTOR TACHOMETER**

Most gyroplanes are equipped with a rotor r.p.m. indicator. Because the pilot does not normally have direct control of rotor r.p.m. in flight, this instrument is most useful on the takeoff roll to determine when there is sufficient rotor speed for liftoff. On gyroplanes not equipped with a rotor tachometer, additional piloting skills are required to sense rotor r.p.m. prior to takeoff.

Certain gyroplane maneuvers require you to know precisely the speed of the rotor system. Performing a jump takeoff in a gyroplane with collective control is one example, as sufficient rotor energy must be available for the successful outcome of the maneuver. When variable collective and a rotor tachometer are used, more efficient rotor operation may be accomplished by using the lowest practical rotor r.p.m. [Figure 18-6]



Figure 18-6. A rotor tachometer can be very useful to determine when rotor r.p.m. is sufficient for takeoff.

### SLIP/SKID INDICATOR

A yaw string attached to the nose of the aircraft and a conventional inclinometer are often used in gyroplanes to assist in maintaining coordinated flight. [Figure 18-7]



Figure 18-7. A string attached to the windshield of gyroplane is often used to indicate rotation about the yaw axis. An inclinometer may also be used.

### AIRSPPEED INDICATOR

Airspeed knowledge is essential and is most easily obtained by an airspeed indicator that is designed for accuracy at low airspeeds. Wind speed indicators have been adapted to many gyroplanes. When no airspeed indicator is used, as in some very basic amateur-built machines, you must have a very acute sense of “q” (impact air pressure against your body).

### ALTIMETER

For the average pilot, it becomes increasingly difficult to judge altitude accurately when more than several hundred feet above the ground. A conventional altimeter may be used to provide an altitude reference when flying at higher altitudes where human perception degrades.

### IFR FLIGHT INSTRUMENTATION

Gyroplane flight into instrument meteorological conditions requires adequate flight instrumentation and navigational systems, just as in any aircraft. Very few gyroplanes have been equipped for this type of operation. The majority of gyroplanes do not meet the stability requirements for single-pilot IFR flight. As larger and more advanced gyroplanes are developed, issues of IFR flight in these aircraft will have to be addressed.

### GROUND HANDLING

The gyroplane is capable of ground taxiing in a manner similar to that of an airplane. A steerable nose wheel, which may be combined with independent main wheel brakes, provides the most common method of control. [Figure 18-8] The use of independent main wheel brakes allows differential braking, or applying more braking to one wheel than the other to achieve tight radius turns. On some gyroplanes, the steerable nose wheel is equipped with a foot-operated brake rather than using main wheel brakes. One limitation of this system is that the nose wheel normally supports only a fraction of the weight of the gyroplane, which greatly reduces braking effectiveness. Another drawback is the inability to use differential braking, which increases the radius of turns.

The rotor blades demand special consideration during ground handling, as turning rotor blades can be a hazard to those nearby. Many gyroplanes have a rotor brake that may be used to slow the rotor after landing, or to secure the blades while parked. A parked gyroplane should never be left with unsecured blades, because even a slight change in wind could cause the blades to turn or flap.



## Rotorcraft Flight Manual

As with most certificated aircraft manufactured after March 1979, FAA-certificated gyroplanes are required to have an approved flight manual. The flight manual describes procedures and limitations that must be adhered to when operating the aircraft. *Specification for Pilot's Operating Handbook*, published by the General Aviation Manufacturers Association (GAMA), provides a recommended format that more recent gyroplane flight manuals follow. [Figure 19-1]

ROTORCRAFT FLIGHT MANUAL	
GENERAL—Presents basic information, such as loading, handling, and preflight of the gyroplane. Also includes definitions, abbreviations, symbology, and terminology explanations.	
LIMITATIONS—Includes operating limitations, instrument markings, color coding, and basic placards necessary for the safe operation of the gyroplane.	
EMERGENCY PROCEDURES—Provides checklists followed by amplified procedures for coping with various types of emergencies or critical situations. Related recommended airspeeds are also included. At the manufacturer's option, a section of abnormal procedures may be included to describe recommendations for handling equipment malfunctions or other abnormalities that are not of an emergency nature.	
NORMAL PROCEDURES—Includes checklists followed by amplified procedures for conducting normal operations. Related recommended airspeeds are also provided.	
PERFORMANCE—Gives performance information appropriate to the gyroplane, plus optional information presented in the most likely order for use in flight.	
WEIGHT AND BALANCE—Includes weighing procedures, weight and balance records, computation instructions, and the equipment list.	
AIRCRAFT AND SYSTEMS DESCRIPTION—Describes the gyroplane and its systems in a format considered by the manufacturer to be most informative.	
HANDLING, SERVICE, AND MAINTENANCE—Includes information on gyroplane inspection periods, preventative maintenance that can be performed by the pilot, ground handling procedures, servicing, cleaning, and care instructions.	
SUPPLEMENTS—Contains information necessary to safely and efficiently operate the gyroplane's various optional systems and equipment.	
SAFETY AND OPERATIONAL TIPS—Includes optional information from the manufacturer of a general nature addressing safety practices and procedures.	

**Figure 19-1.** The FAA-approved flight manual may contain as many as ten sections, as well as an optional alphabetical index.

This format is the same as that used by helicopters, which is explained in depth in Chapter 6—Rotorcraft Flight Manual (Helicopter).

Amateur-built gyroplanes may have operating limitations but are not normally required to have an approved flight manual. One exception is an exemption granted by the FAA that allows the commercial use of two-place, amateur-built gyroplanes for instructional purposes. One of the conditions of this exemption is to have an approved flight manual for the aircraft. This manual is to be used for training purposes, and must be carried in the gyroplane at all times.

### USING THE FLIGHT MANUAL

The flight manual is required to be on board the aircraft to guarantee that the information contained therein is readily available. For the information to be of value, you must be thoroughly familiar with the manual and be able to read and properly interpret the various charts and tables.

### WEIGHT AND BALANCE SECTION

The weight and balance section of the flight manual contains information essential to the safe operation of the gyroplane. Careful consideration must be given to the weight of the passengers, baggage, and fuel prior to each flight. In conducting weight and balance computations, many of the terms and procedures are similar to those used in helicopters. These are further explained in Chapter 7—Weight and Balance. In any aircraft, failure to adhere to the weight and balance limitations prescribed by the manufacturer can be extremely hazardous.

	Weight (pounds)	Mo (-in./1,000)
Basic Empty Weight	1,315	153.9
Pilot	175	9.1
Passenger	160	13.4
Baggage	0	0
Total Aircraft (Less Fuel)	1,650	176.4
Max Gross Weight = 1,800 lbs.		

**Figure 19-3.** Loading of the sample aircraft, less fuel.



## HEIGHT/VELOCITY DIAGRAM

Like helicopters, gyroplanes have a height/velocity diagram that defines what speed and altitude combinations allow for a safe landing in the event of an engine failure. [Figure 19-6]

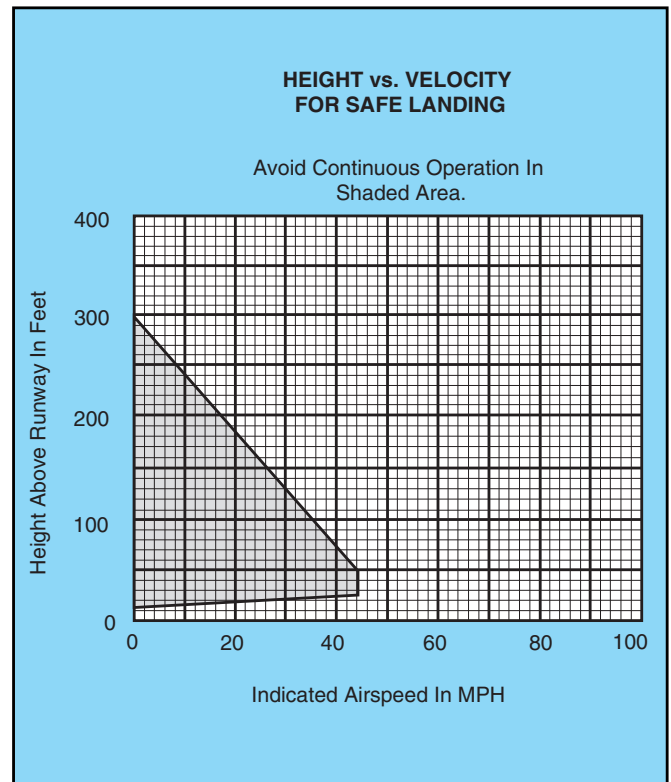
During an engine-out landing, the cyclic flare is used to arrest the vertical velocity of the aircraft and most of the forward velocity. On gyroplanes with a manual collective control, increasing blade pitch just prior to touchdown can further reduce ground roll. Typically, a gyroplane has a lower rotor disc loading than a helicopter, which provides a slower rate of descent in autorotation. The power required to turn the main transmission, tail rotor transmission, and tail rotor also add to the higher descent rate of a helicopter in autorotation as compared with that of a gyroplane.

## EMERGENCY SECTION

Because in-flight emergencies may not allow enough time to reference the flight manual, the emergency section should be reviewed periodically to maintain familiarity with these procedures. Many aircraft also use placards and instrument markings in the cockpit, which provide important information that may not be committed to memory.

## HANG TEST

The proper weight and balance of a gyroplane without a flight manual is normally determined by conducting a hang test of the aircraft. This is achieved by removing the rotor blades and suspending the aircraft by its teeter bolt, free from contact with the ground. A measurement is then taken, either at the keel or the rotor mast, to determine how many degrees from level the

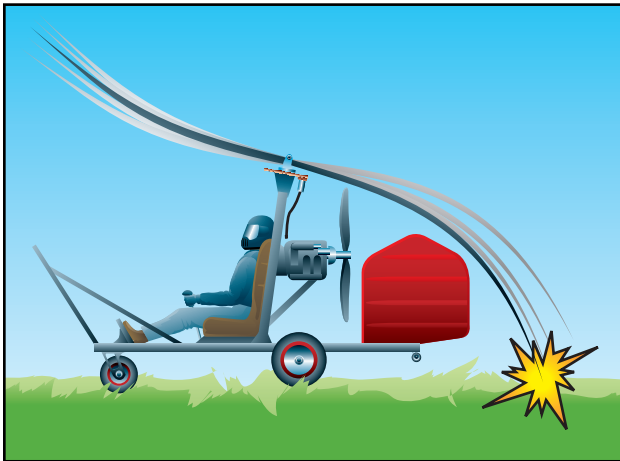


**Figure 19-6. Operations within the shaded area of a height/velocity diagram may not allow for a safe landing and are to be avoided.**

gyroplane hangs. This number must be within the range specified by the manufacturer. For the test to reflect the true balance of the aircraft, it is important that it be conducted using the actual weight of the pilot and all gear normally carried in flight. Additionally, the measurement should be taken both with the fuel tank full and with it empty to ensure that fuel burn does not affect the loading.

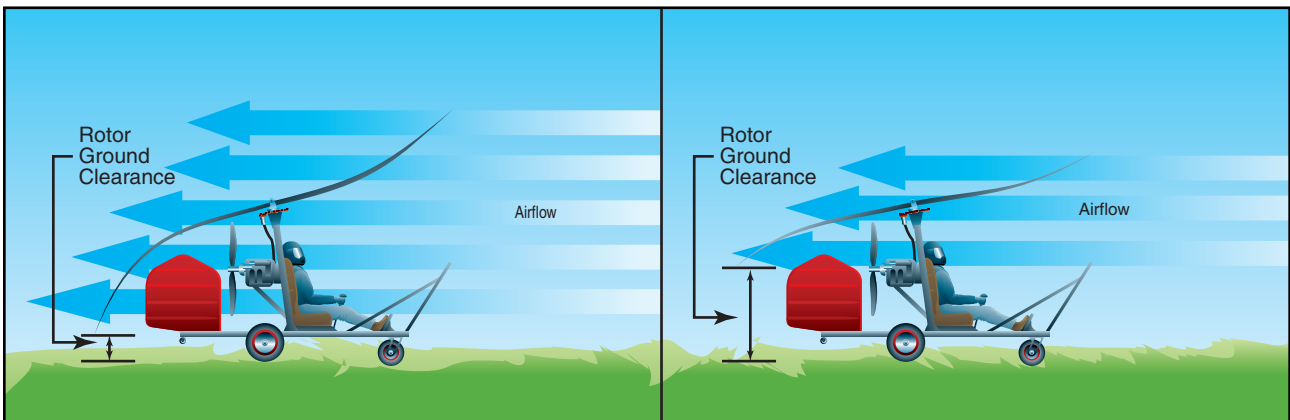


bend. Because the system is operating at low r.p.m., there is not enough centrifugal force acting on the blades to keep them rigid. The shock of hitting the teeter stops combined with uneven lift along the length of the blade causes an undulation to begin, which can increase in severity if allowed to progress. In extreme cases, a rotor blade may strike the ground or propeller. [Figure 20-2]



**Figure 20-2.** Taxiing too fast or gusting winds can cause blade flap in a slow turning rotor. If not controlled, a rotor blade may strike the ground.

To avoid the onset of blade flap, always taxi the gyroplane at slow speeds when the rotor system is at low r.p.m. Consideration must also be given to wind speed and direction. If taxiing into a 10-knot headwind, for example, the airflow through the rotor will be 10 knots faster than the forward speed of the gyroplane, so the taxi speed should be adjusted accordingly. When prerotating the rotor by taxiing with the rotor disc tilted aft, allow the rotor to accelerate slowly and smoothly. In the event blade flap is encountered, apply forward cyclic to reduce the rotor disc angle and slow the gyroplane by reducing throttle and applying the brakes, if needed. [Figure 20-3]



**Figure 20-3.** Decreasing the rotor disc angle of attack with forward cyclic can reduce the excessive amount of airflow causing the blade flap. This also allows greater clearance between the rotor blades and the surface behind the gyroplane, minimizing the chances of a blade striking the ground.

## BEFORE TAKEOFF

For the amateur-built gyroplane using single ignition and a fixed trim system, the before takeoff check is quite simple. The engine should be at normal operating temperature, and the area must be clear for prerotation. Certificated gyroplanes using conventional aircraft engines have a checklist that includes items specific to the powerplant. These normally include, but are not limited to, checks for magneto drop, carburetor heat, and, if a constant speed propeller is installed, that it be cycled for proper operation.

Following the engine run-up is the procedure for accomplishing prerotation. This should be reviewed and committed to memory, as it typically requires both hands to perform.

## PREROTATION

Prerotation of the rotor can take many forms in a gyroplane. The most basic method is to turn the rotor blades by hand. On a typical gyroplane with a counter-clockwise rotating rotor, prerotation by hand is done on the right side of the rotor disk. This allows body movement to be directed away from the propeller to minimize the risk of injury. Other methods of prerotation include using mechanical, electrical, or hydraulic means for the initial blade spin-up. Many of these systems can achieve only a portion of the rotor speed that is necessary for takeoff. After the prerotator is disengaged, taxi the gyroplane with the rotor disk tilted aft to allow airflow through the rotor. This increases rotor speed to flight r.p.m. In windy conditions, facing the gyroplane into the wind during prerotation assists in achieving the highest possible rotor speed from the prerotator. A factor often overlooked that can negatively affect the prerotation speed is the cleanliness of the rotor blades. For maximum efficiency, it is recommended that the rotor blades be cleaned periodically. By obtaining the maximum possible rotor speed through the use of proper prerotation techniques, you



minimize the length of the ground roll that is required to get the gyroplane airborne.

The prerotators on certificated gyroplanes remove the possibility of blade flap during prerotation. Before the clutch can be engaged, the pitch must be removed from the blades. The rotor is then prerotated with a  $0^\circ$  angle of attack on the blades, which prevents lift from being produced and precludes the possibility of flapping. When the desired rotor speed is achieved, blade pitch is increased for takeoff.

## TAKEOFF

Takeoffs are classified according to the takeoff surface, obstructions, and atmospheric conditions. Each type of takeoff assumes that certain conditions exist. When conditions dictate, a combination of takeoff techniques can be used. Two important speeds used for takeoff and initial climbout are  $V_X$  and  $V_Y$ .  $V_X$  is defined as the speed that provides the best angle of climb, and will yield the maximum altitude gain over a given distance. This speed is normally used when obstacles on the ground are a factor. Maintaining  $V_Y$  speed ensures the aircraft will climb at its maximum rate, providing the most altitude gain for a given period of time. [Figure 20-4] Prior to any takeoff or maneuver, you should ensure that the area is clear of other traffic.

## NORMAL TAKEOFF

The normal takeoff assumes that a prepared surface of adequate length is available and that there are no high obstructions to be cleared within the takeoff path. The normal takeoff for most amateur-built gyroplanes is accomplished by prerotating to sufficient rotor r.p.m. to prevent blade flapping and tilting the rotor back with cyclic control. Using a speed of 20 to 30 m.p.h., allow the rotor to accelerate and begin producing lift. As lift increases, move the cyclic forward to decrease the pitch angle on the rotor disc. When appreciable lift is being produced, the nose of the aircraft rises, and you can feel an increase in drag. Using coordinated throttle and flight control inputs, balance the gyroplane on the main gear without the nose wheel or tail wheel in contact with the surface. At this point, smoothly increase power to full thrust and hold the nose at takeoff attitude with cyclic pressure. The gyroplane will lift off at or near the minimum power required speed for the aircraft.  $V_X$  should be used for the initial climb, then  $V_Y$  for the remainder of the climb phase.

A normal takeoff for certificated gyroplanes is accomplished by prerotating to a rotor r.p.m. slightly above that required for flight and disengaging the rotor drive. The brakes are then released and full power is applied. Lift off will not occur until the blade pitch is increased to the normal in-flight setting and the rotor disk tilted

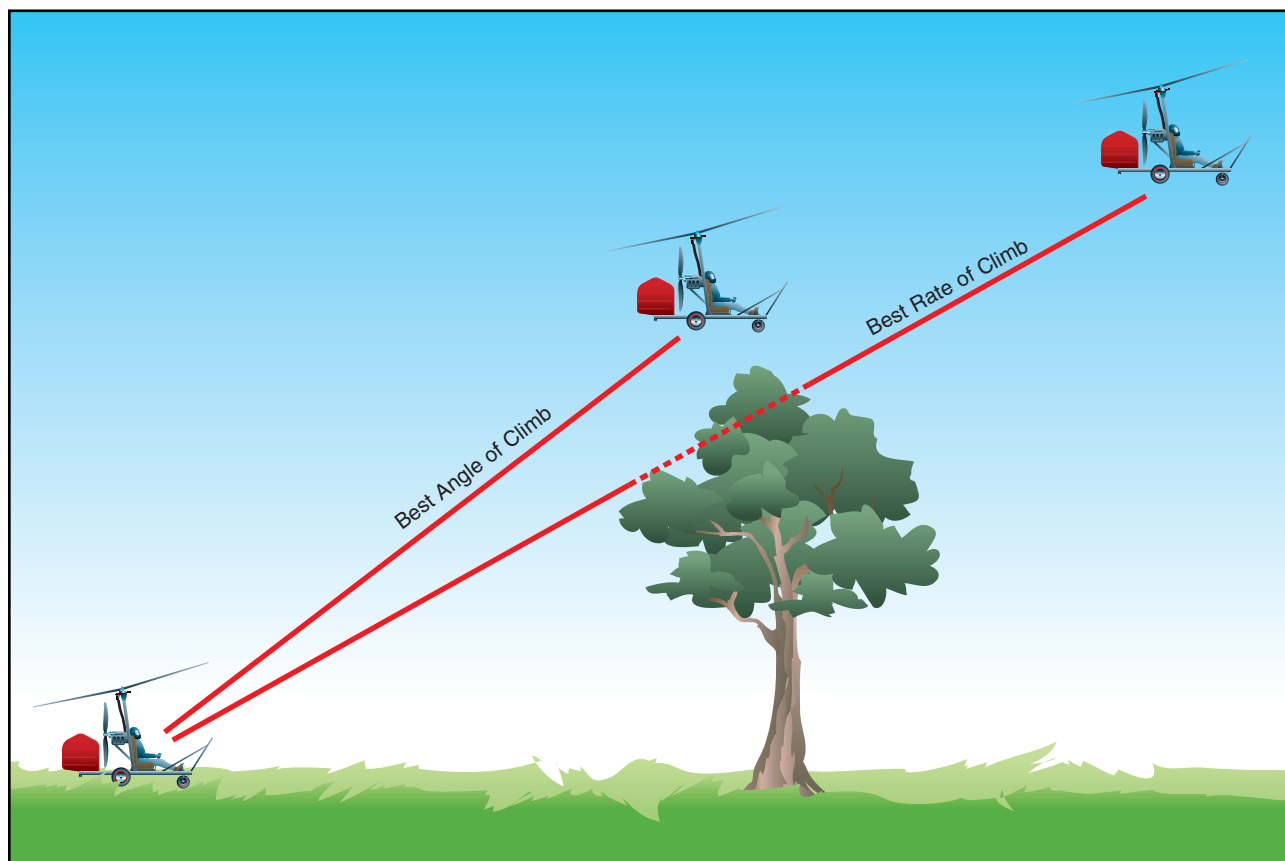


Figure 20-4. Best angle-of-climb ( $V_X$ ) speed is used when obstacles are a factor.  $V_Y$  provides the most altitude gain for a given amount of time.

aft. This is normally accomplished at approximately 30 to 40 m.p.h. The gyroplane should then be allowed to accelerate to  $V_X$  for the initial climb, followed by  $V_Y$  for the remainder of the climb. On any takeoff in a gyroplane, engine torque causes the aircraft to roll opposite the direction of propeller rotation, and adequate compensation must be made.

### CROSSWIND TAKEOFF

A crosswind takeoff is much like a normal takeoff, except that you have to use the flight controls to compensate for the crosswind component. The term crosswind component refers to that part of the wind which acts at right angles to the takeoff path. Before attempting any crosswind takeoff, refer to the flight manual, if available, or the manufacturer's recommendations for any limitations.

Begin the maneuver by aligning the gyroplane into the wind as much as possible. At airports with wide runways, you might be able to angle your takeoff roll down the runway to take advantage of as much headwind as you can. As airspeed increases, gradually tilt the rotor into the wind and use rudder pressure to maintain runway heading. In most cases, you should accelerate to a speed slightly faster than normal liftoff speed. As you reach takeoff speed, the downwind wheel lifts off the ground first, followed by the upwind wheel. Once airborne, remove the cross-control inputs and establish a crab, if runway heading is to be maintained. Due to the maneuverability of the gyroplane, an immediate turn into the wind after lift off can be safely executed, if this does not cause a conflict with existing traffic.

### COMMON ERRORS FOR NORMAL AND CROSSWIND TAKEOFFS

1. Failure to check rotor for proper operation, track, and r.p.m. prior to takeoff.
2. Improper initial positioning of flight controls.
3. Improper application of power.
4. Poor directional control.
5. Failure to lift off at proper airspeed.
6. Failure to establish and maintain proper climb attitude and airspeed.
7. Drifting from the desired ground track during the climb.

### SHORT-FIELD TAKEOFF

Short-field takeoff and climb procedures may be required when the usable takeoff surface is short, or when it is restricted by obstructions, such as trees, powerlines, or buildings, at the departure end. The technique is identical to the normal takeoff, with performance being optimized during each phase. Using the help from wind and propwash, the maximum rotor r.p.m. should be attained from the prerotator and full

power applied as soon as appreciable lift is felt.  $V_X$  climb speed should be maintained until the obstruction is cleared. Familiarity with the rotor acceleration characteristics and proper technique are essential for optimum short-field performance.

If the prerotator is capable of spinning the rotor in excess of normal flight r.p.m., the stored energy may be used to enhance short-field performance. Once maximum rotor r.p.m. is attained, disengage the rotor drive, release the brakes, and apply power. As airspeed and rotor r.p.m. increase, apply additional power until full power is achieved. While remaining on the ground, accelerate the gyroplane to a speed just prior to  $V_X$ . At that point, tilt the disk aft and increase the blade pitch to the normal in-flight setting. The climb should be at a speed just under  $V_X$  until rotor r.p.m. has dropped to normal flight r.p.m. or the obstruction has been cleared. When the obstruction is no longer a factor, increase the airspeed to  $V_Y$ .

### COMMON ERRORS

1. Failure to position gyroplane for maximum utilization of available takeoff area.
2. Failure to check rotor for proper operation, track, and r.p.m. prior to takeoff.
3. Improper initial positioning of flight controls.
4. Improper application of power.
5. Improper use of brakes.
6. Poor directional control.
7. Failure to lift off at proper airspeed.
8. Failure to establish and maintain proper climb attitude and airspeed.
9. Drifting from the desired ground track during the climb.

### HIGH-ALTITUDE TAKEOFF

A high-altitude takeoff is conducted in a manner very similar to that of the short-field takeoff, which achieves maximum performance from the aircraft during each phase of the maneuver. One important consideration is that at higher altitudes, rotor r.p.m. is higher for a given blade pitch angle. This higher speed is a result of thinner air, and is necessary to produce the same amount of lift. The inertia of the excess rotor speed should not be used in an attempt to enhance climb performance. Another important consideration is the effect of altitude on engine performance. As altitude increases, the amount of oxygen available for combustion decreases. In **normally aspirated** engines, it may be necessary to

**Normally Aspirated**—An engine that does not compensate for decreases in atmospheric pressure through turbocharging or other means.

adjust the fuel/air mixture to achieve the best possible power output. This process is referred to as “leaning the mixture.” If you are considering a high-altitude takeoff, and it appears that the climb performance limit of the gyroplane is being approached, do not attempt a takeoff until more favorable conditions exist.

### SOFT-FIELD TAKEOFF

A soft field may be defined as any takeoff surface that measurably retards acceleration during the takeoff roll. The objective of the soft-field takeoff is to transfer the weight of the aircraft from the landing gear to the rotor as quickly and smoothly as possible to eliminate the drag caused by surfaces, such as tall grass, soft dirt, or snow. This takeoff requires liftoff at a speed just above the minimum level flight speed for the aircraft. Due to design, many of the smaller gyroplanes have a limited pitch attitude available, as tail contact with the ground prevents high pitch attitudes until in flight. At minimum level flight speed, the pitch attitude is often such that the tail wheel is lower than the main wheels. When performing a soft-field takeoff, these aircraft require slightly higher liftoff airspeeds to allow for proper tail clearance.

### COMMON ERRORS

1. Failure to check rotor for proper operation, track, and r.p.m. prior to takeoff.
2. Improper initial positioning of flight controls.
3. Improper application of power.
4. Allowing gyroplane to lose momentum by slowing or stopping on takeoff surface prior to initiating takeoff.
5. Poor directional control.
6. Improper pitch attitude during lift-off.
7. Settling back to takeoff surface after becoming airborne.
8. Failure to establish and maintain proper climb attitude and airspeed.
9. Drifting from the desired ground track during the climb.

## BASIC FLIGHT MANEUVERS

Conducting flight maneuvers in a gyroplane is different than in most other aircraft. Because of the wide variety in designs, many gyroplanes have only basic instruments available, and the pilot is often exposed to the airflow. In addition, the visual clues found on other aircraft, such as cowlings, wings, and windshields might not be part of your gyroplane’s design. Therefore, much more reliance is placed on pilot interpretation of flight attitude and the “feel” of the gyroplane than in other types of aircraft.

Acquiring the skills to precisely control a gyroplane can be a challenging and rewarding experience, but requires dedication and the direction of a competent instructor.

### STRAIGHT-AND-LEVEL FLIGHT

Straight-and-level flight is conducted by maintaining a constant altitude and a constant heading. In flight, a gyroplane essentially acts as a plumb suspended from the rotor. As such, torque forces from the engine cause the airframe to be deflected a few degrees out of the vertical plane. This very slight “out of vertical” condition should be ignored and the aircraft flown to maintain a constant heading.

The throttle is used to control airspeed. In level flight, when the airspeed of a gyroplane increases, the rotor disc angle of attack must be decreased. This causes pitch control to become increasingly more sensitive. [Figure 20-7] As this disc angle becomes very small, it is possible to overcontrol a gyroplane when encountering turbulence. For this reason, when extreme turbulence is encountered or expected, airspeed should be decreased. Even in normal conditions, a gyroplane requires constant attention to maintain straight-and-level flight. Although more stable than helicopters, gyroplanes are less stable than airplanes. When cyclic trim is available, it should be used to relieve any stick forces required during stabilized flight.

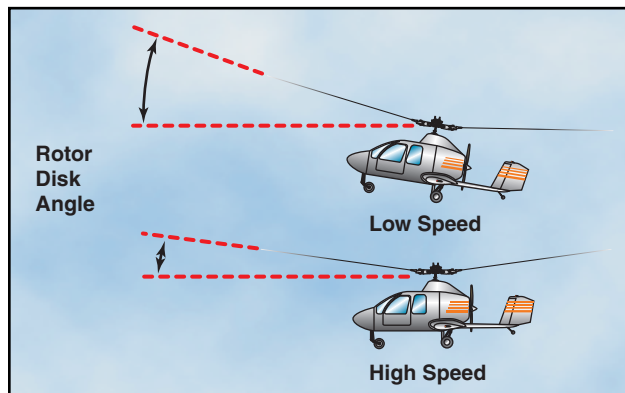


Figure 20-7. The angle of the rotor disc decreases at higher cruise speeds, which increases pitch control sensitivity.

### CLIMBS

A climb is achieved by adding power in excess of what is required for straight-and-level flight at a particular airspeed. The amount of excess power used is directly proportional to the climb rate. For maneuvers when maximum performance is desired, two important climb speeds are best angle-of-climb speed and best rate-of-climb speed.



Because a gyroplane cannot be stalled, it may be tempting to increase the climb rate by decreasing airspeed. This practice, however, is self-defeating. Operating below the best angle-of-climb speed causes a diminishing rate of climb. In fact, if a gyroplane is slowed to the minimum level flight speed, it requires full power just to maintain altitude. Operating in this performance realm, sometimes referred to as the “backside of the power curve,” is desirable in some maneuvers, but can be hazardous when maximum climb performance is required. For further explanation of a gyroplane power curve, see Flight at Slow Airspeeds, which is discussed later in this chapter.

## DESCENTS

A descent is the result of using less power than that required for straight-and-level flight at a particular airspeed. Varying engine power during a descent allows you to choose a variety of descent profiles. In a power-off descent, the minimum descent rate is achieved by using the airspeed that would normally be used for level flight at minimum power, which is also very close to the speed used for the best angle of climb. When distance is a factor during a power-off descent, maximum gliding distance can be achieved by maintaining a speed very close to the best rate-of-climb airspeed. Because a gyroplane can be safely flown down to zero airspeed, a common error in this type of descent is attempting to extend the glide by raising the pitch attitude. The result is a higher rate of descent and less distance being covered. For this reason, proper glide speed should be adhered to closely. Should a strong headwind exist, while attempting to achieve the maximum distance during a glide, a rule of thumb to achieve the greatest distance is to increase the glide speed by approximately 25 percent of the headwind. The attitude of the gyroplane for best glide performance is learned with experience, and slight pitch adjustments are made for the proper airspeed. If a descent is needed to lose excess altitude, slowing the gyroplane to below the best glide speed increases the rate of descent. Typically, slowing to zero airspeed results in a descent rate twice that of maintaining the best glide speed.

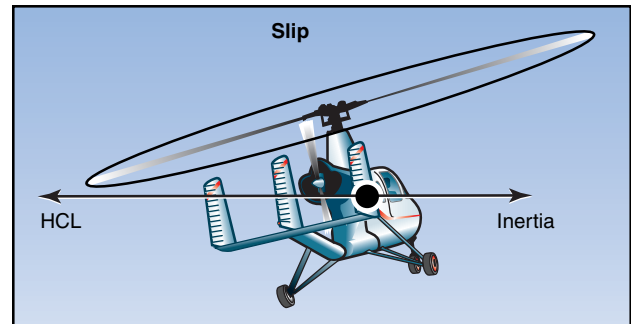
## TURNS

Turns are made in a gyroplane by banking the rotor disc with cyclic control. Once the area, in the direction of the turn, has been cleared for traffic, apply sideward pressure on the cyclic until the desired bank angle is achieved. The speed at which the gyroplane enters the bank is dependent on how far the cyclic is displaced. When the desired bank angle is reached, return the cyclic to the neutral position. The rudder pedals are used to keep the gyroplane in longitudinal trim throughout the turn, but not to assist in establishing the turn.

The bank angle used for a turn directly affects the rate of turn. As the bank is steepened, the turn rate increases, but more power is required to maintain altitude. A bank angle can be reached where all available power is required, with any further increase in bank resulting in a loss of airspeed or altitude. Turns during a climb should be made at the minimum angle of bank necessary, as higher bank angles would require more power that would otherwise be available for the climb. Turns while gliding increase the rate of descent and may be used as an effective way of losing excess altitude.

## SLIPS

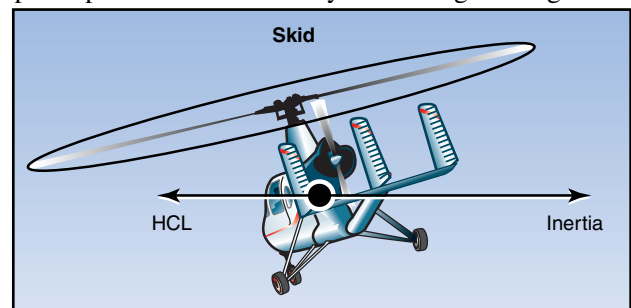
A slip occurs when the gyroplane slides sideways toward the center of the turn. [Figure 20-8] It is caused by an insufficient amount of rudder pedal in the direction of the turn, or too much in the direction opposite the turn. In other words, holding improper rudder pedal pressure keeps the nose from following the turn, the gyroplane slips sideways toward the center of the turn.



**Figure 20-8.** During a slip, the rate of turn is too slow for the angle of bank used, and the horizontal component of lift (HCL) exceeds inertia. You can reestablish equilibrium by decreasing the angle of bank, increasing the rate of turn by applying rudder pedal, or a combination of the two.

## SKIDS

A skid occurs when the gyroplane slides sideways away from the center of the turn. [Figure 20-9] It is caused by too much rudder pedal pressure in the direction of the turn, or by too little in the direction opposite the turn. If the gyroplane is forced to turn faster with increased pedal pressure instead of by increasing the degree of



**Figure 20-9.** During a skid, inertia exceeds the HCL. To reestablish equilibrium, increase the bank angle or reduce the rate of turn by applying rudder pedal. You may also use a combination of these two corrections.

bank, it skids sideways away from the center of the turn instead of flying in its normal curved pattern.

## COMMON ERRORS DURING BASIC FLIGHT MANEUVERS

1. Improper coordination of flight controls.
2. Failure to cross-check and correctly interpret outside and instrument references.
3. Using faulty trim technique.

## STEEP TURNS

A steep turn is a performance maneuver used in training that consists of a turn in either direction at a bank angle of approximately 40°. The objective of performing steep turns is to develop smoothness, coordination, orientation, division of attention, and control techniques.

Prior to initiating a steep turn, or any other flight maneuver, first complete a clearing turn to check the area for traffic. To accomplish this, you may execute either one 180° turn or two 90° turns in opposite directions. Once the area has been cleared, roll the gyroplane into a 40° angle-of-bank turn while smoothly adding power and slowly moving the cyclic aft to maintain altitude. Maintain coordinated flight with proper rudder pedal pressure. Throughout the turn, cross-reference visual cues outside the gyroplane with the flight instruments, if available, to maintain a constant altitude and angle of bank. Anticipate the roll-out by leading the roll-out heading by approximately 20°. Using section lines or prominent landmarks to aid in orientation can be helpful in rolling out on the proper heading. During roll-out, gradually return the cyclic to the original position and reduce power to maintain altitude and airspeed.

## COMMON ERRORS

1. Improper bank and power coordination during entry and rollout.
2. Uncoordinated use of flight controls.
3. Exceeding manufacturer's recommended maximum bank angle.
4. Improper technique in correcting altitude deviations.
5. Loss of orientation.
6. Excessive deviation from desired heading during rollout.

## GROUND REFERENCE MANEUVERS

Ground reference maneuvers are training exercises flown to help you develop a division of attention between the flight path and ground references, while controlling the gyroplane and watching for other

aircraft in the vicinity. Prior to each maneuver, a clearing turn should be accomplished to ensure the practice area is free of conflicting traffic.

## RECTANGULAR COURSE

The rectangular course is a training maneuver in which the ground track of the gyroplane is equidistant from all sides of a selected rectangular area on the ground. [Figure 20-10] While performing the maneuver, the altitude and airspeed should be held constant. The rectangular course helps you to develop a recognition of a drift toward or away from a line parallel to the intended ground track. This is helpful in recognizing drift toward or from an airport runway during the various legs of the airport traffic pattern.

For this maneuver, pick a square or rectangular field, or an area bounded on four sides by section lines or roads, where the sides are approximately a mile in length. The area selected should be well away from other air traffic. Fly the maneuver approximately 600 to 1,000 feet above the ground, which is the altitude usually required for an airport traffic pattern. You should fly the gyroplane parallel to and at a uniform distance, about one-fourth to one-half mile, from the field boundaries, not above the boundaries. For best results, position your flight path outside the field boundaries just far enough away that they may be easily observed. You should be able to see the edges of the selected field while seated in a normal position and looking out the side of the gyroplane during either a left-hand or right-hand course. The distance of the ground track from the edges of the field should be the same regardless of whether the course is flown to the left or right. All turns should be started when your gyroplane is abeam the corners of the field boundaries. The bank normally should not exceed 30°.

Although the rectangular course may be entered from any direction, this discussion assumes entry on a downwind heading. As you approach the field boundary on the downwind leg, you should begin planning for your turn to the crosswind leg. Since you have a tailwind on the downwind leg, the gyroplane's groundspeed is increased (position 1). During the turn onto the crosswind leg, which is the equivalent of the base leg in a traffic pattern, the wind causes the gyroplane to drift away from the field. To counteract this effect, the roll-in should be made at a fairly fast rate with a relatively steep bank (position 2).

As the turn progresses, the tailwind component decreases, which decreases the groundspeed. Consequently, the bank angle and rate of turn must be reduced gradually to ensure that upon completion of the turn, the crosswind ground track continues to be the same distance from the edge of the field. Upon completion of the turn, the gyroplane should be level and

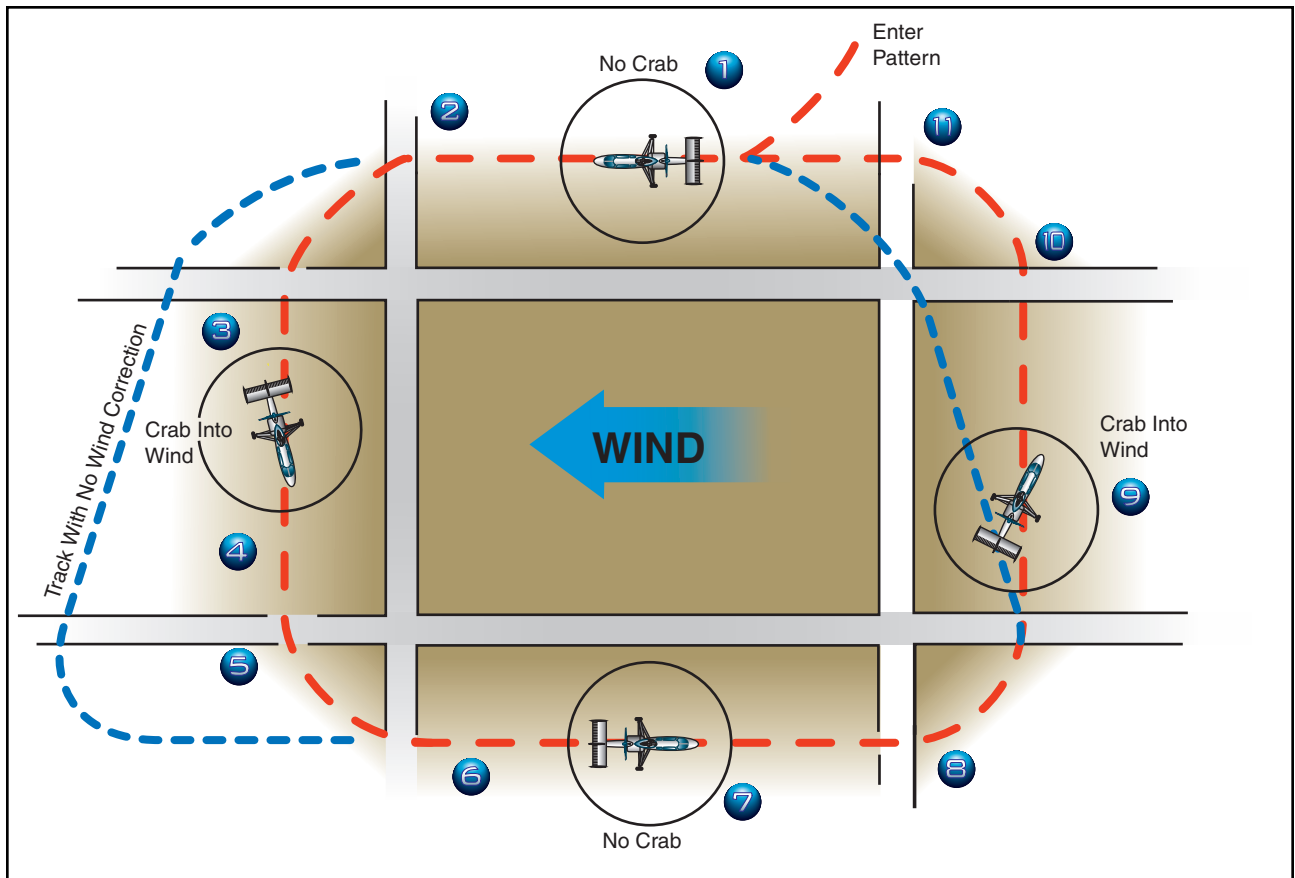


Figure 20-10. Rectangular course. The numbered positions in the text refer to the numbers in this illustration.

aligned with the downwind corner of the field. However, since the crosswind is now pushing you away from the field, you must establish the proper drift correction by flying slightly into the wind. Therefore, the turn to crosswind should be greater than a  $90^\circ$  change in heading (position 3). If the turn has been made properly, the field boundary again appears to be one-fourth to one-half mile away. While on the crosswind leg, the wind correction should be adjusted, as necessary, to maintain a uniform distance from the field boundary (position 4).

As the next field boundary is being approached (position 5), plan the turn onto the upwind leg. Since a wind correction angle is being held into the wind and toward the field while on the crosswind leg, this next turn requires a turn of less than  $90^\circ$ . Since the crosswind becomes a headwind, causing the groundspeed to decrease during this turn, the bank initially must be medium and progressively decreased as the turn proceeds. To complete the turn, time the rollout so that the gyroplane becomes level at a point aligned with the corner of the field just as the longitudinal axis of the gyroplane again becomes parallel to the field boundary (position 6). The distance from the field boundary should be the same as on the other sides of the field.

On the upwind leg, the wind is a headwind, which results in an decreased groundspeed (position 7). Consequently, enter the turn onto the next leg with a fairly slow rate of roll-in, and a relatively shallow bank (position 8). As the turn progresses, gradually increase the bank angle because the headwind component is diminishing, resulting in an increasing groundspeed. During and after the turn onto this leg, the wind tends to drift the gyroplane toward the field boundary. To compensate for the drift, the amount of turn must be less than  $90^\circ$  (position 9).

Again, the rollout from this turn must be such that as the gyroplane becomes level, the nose of the gyroplane is turned slightly away the field and into the wind to correct for drift. The gyroplane should again be the same distance from the field boundary and at the same altitude, as on other legs. Continue the crosswind leg until the downwind leg boundary is approached (position 10). Once more you should anticipate drift and turning radius. Since drift correction was held on the crosswind leg, it is necessary to turn greater than  $90^\circ$  to align the gyroplane parallel to the downwind leg boundary. Start this turn with a medium bank angle, gradually increasing it to a steeper bank as the turn progresses. Time the rollout to assure paralleling the



boundary of the field as the gyroplane becomes level (position 11).

If you have a direct headwind or tailwind on the upwind and downwind leg, drift should not be encountered. However, it may be difficult to find a situation where the wind is blowing exactly parallel to the field boundaries. This makes it necessary to use a slight wind correction angle on all the legs. It is important to anticipate the turns to compensate for groundspeed, drift, and turning radius. When the wind is behind the gyroplane, the turn must be faster and steeper; when it is ahead of the gyroplane, the turn must be slower and shallower. These same techniques apply while flying in an airport traffic pattern.

### S-TURNS

Another training maneuver you might use is the S-turn, which helps you correct for wind drift in turns. This maneuver requires turns to the left and right. The reference line used, whether a road, railroad, or fence, should be straight for a considerable distance and should extend as nearly perpendicular to the wind as possible.

The object of S-turns is to fly a pattern of two half circles of equal size on opposite sides of the reference line. [Figure 20-11] The maneuver should be performed at a constant altitude of 600 to 1,000 feet above the terrain. S-turns may be started at any point; however, during early training it may be beneficial to start on a downwind heading. Entering downwind permits the immediate selection of the steepest bank

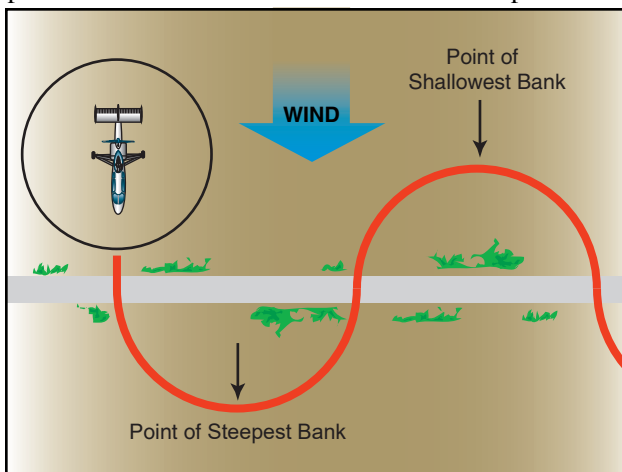


Figure 20-11. S-turns across a road.

that is desired throughout the maneuver. The discussion that follows is based on choosing a reference line that is perpendicular to the wind and starting the maneuver on a downwind heading.

As the gyroplane crosses the reference line, immediately establish a bank. This initial bank is the steepest

used throughout the maneuver since the gyroplane is headed directly downwind and the groundspeed is at its highest. Gradually reduce the bank, as necessary, to describe a ground track of a half circle. Time the turn so that as the rollout is completed, the gyroplane is crossing the reference line perpendicular to it and heading directly upwind. Immediately enter a bank in the opposite direction to begin the second half of the "S." Since the gyroplane is now on an upwind heading, this bank (and the one just completed before crossing the reference line) is the shallowest in the maneuver. Gradually increase the bank, as necessary, to describe a ground track that is a half circle identical in size to the one previously completed on the other side of the reference line. The steepest bank in this turn should be attained just prior to rollout when the gyroplane is approaching the reference line nearest the downwind heading. Time the turn so that as the rollout is complete, the gyroplane is perpendicular to the reference line and is again heading directly downwind.

In summary, the angle of bank required at any given point in the maneuver is dependent on the groundspeed. The faster the groundspeed, the steeper the bank; the slower the groundspeed, the shallower the bank. To express it another way, the more nearly the gyroplane is to a downwind heading, the steeper the bank; the more nearly it is to an upwind heading, the shallower the bank. In addition to varying the angle of bank to correct for drift in order to maintain the proper radius of turn, the gyroplane must also be flown with a drift correction angle (crab) in relation to its ground track; except of course, when it is on direct upwind or downwind headings or there is no wind. One would normally think of the fore and aft axis of the gyroplane as being tangent to the ground track pattern at each point. However, this is not the case. During the turn on the upwind side of the reference line (side from which the wind is blowing), crab the nose of the gyroplane toward the outside of the circle. During the turn on the downwind side of the reference line (side of the reference line opposite to the direction from which the wind is blowing), crab the nose of the gyroplane toward the inside of the circle. In either case, it is obvious that the gyroplane is being crabbed into the wind just as it is when trying to maintain a straight ground track. The amount of crab depends upon the wind velocity and how nearly the gyroplane is to a crosswind position. The stronger the wind, the greater the crab angle at any given position for a turn of a given radius. The more nearly the gyroplane is to a crosswind position, the greater the crab angle. The maximum crab angle should be at the point of each half circle farthest from the reference line.

A standard radius for S-turns cannot be specified, since the radius depends on the airspeed of the gyroplane, the

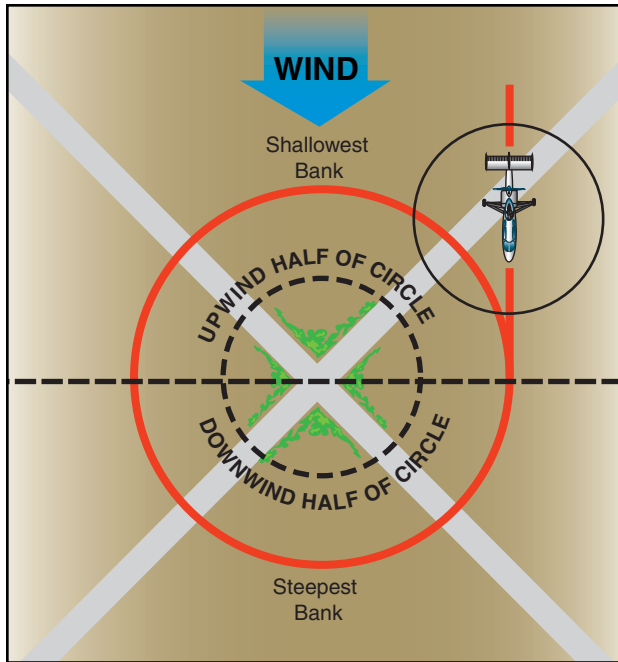


Figure 20-12. Turns around a point.

velocity of the wind, and the initial bank chosen for entry.

### TURNS AROUND A POINT

This training maneuver requires you to fly constant radius turns around a preselected point on the ground using a maximum bank of approximately 40°, while maintaining a constant altitude. [Figure 20-12] Your objective, as in other ground reference maneuvers, is to develop the ability to subconsciously control the gyroplane while dividing attention between the flight path and ground references, while still watching for other air traffic in the vicinity.

The factors and principles of drift correction that are involved in S-turns are also applicable in this maneuver. As in other ground track maneuvers, a constant radius around a point will, if any wind exists, require a constantly changing angle of bank and angles of wind correction. The closer the gyroplane is to a direct downwind heading where the groundspeed is greatest, the steeper the bank, and the faster the rate of turn required to establish the proper wind correction angle. The more nearly it is to a direct upwind heading where the groundspeed is least, the shallower the bank, and the slower the rate of turn required to establish the proper wind correction angle. It follows then, that throughout the maneuver, the bank and rate of turn must be gradually varied in proportion to the groundspeed.

The point selected for turns around a point should be prominent and easily distinguishable, yet small enough to present a precise reference. Isolated trees,

crossroads, or other similar small landmarks are usually suitable. The point should be in an area away from communities, livestock, or groups of people on the ground to prevent possible annoyance or hazard to others. Since the maneuver is performed between 600 and 1,000 feet AGL, the area selected should also afford an opportunity for a safe emergency landing in the event it becomes necessary.

To enter turns around a point, fly the gyroplane on a downwind heading to one side of the selected point at a distance equal to the desired radius of turn. When any significant wind exists, it is necessary to roll into the initial bank at a rapid rate so that the steepest bank is attained abeam the point when the gyroplane is headed directly downwind. By entering the maneuver while heading directly downwind, the steepest bank can be attained immediately. Thus, if a bank of 40° is desired, the initial bank is 40° if the gyroplane is at the correct distance from the point. Thereafter, the bank is gradually shallowed until the point is reached where the gyroplane is headed directly upwind. At this point, the bank is gradually steepened until the steepest bank is again attained when heading downwind at the initial point of entry.

Just as S-turns require that the gyroplane be turned into the wind, in addition to varying the bank, so do turns around a point. During the downwind half of the circle, the gyroplane's nose must be progressively turned toward the inside of the circle; during the upwind half, the nose must be progressively turned toward the outside. The downwind half of the turn around the point may be compared to the downwind side of the S-turn, while the upwind half of the turn around a point may be compared to the upwind side of the S-turn.

As you become experienced in performing turns around a point and have a good understanding of the effects of wind drift and varying of the bank angle and wind correction angle, as required, entry into the maneuver may be from any point. When entering this maneuver at any point, the radius of the turn must be carefully selected, taking into account the wind velocity and groundspeed, so that an excessive bank is not required later on to maintain the proper ground track.

### COMMON ERRORS DURING GROUND REFERENCE MANEUVERS

1. Faulty entry technique.
2. Poor planning, orientation, or division of attention.
3. Uncoordinated flight control application.
4. Improper correction for wind drift.

5. An unsymmetrical ground track during S-turns across a road.
6. Failure to maintain selected altitude or airspeed.
7. Selection of a ground reference where there is no suitable emergency landing site.

## FLIGHT AT SLOW AIRSPEEDS

The purpose of maneuvering during slow flight is to help you develop a feel for controlling the gyroplane at slow airspeeds, as well as gain an understanding of how load factor, pitch attitude, airspeed, and altitude control relate to each other.

Like airplanes, gyroplanes have a specific amount of power that is required for flight at various airspeeds, and a fixed amount of power available from the engine. This data can be charted in a graph format. [Figure 20-13] The lowest point of the power required curve represents the speed at which the gyroplane will fly in level flight while using the least amount of power. To fly faster than this speed, or slower, requires more power. While practicing slow flight in a gyroplane, you will likely be operating in the performance realm on the chart that is left of the minimum power required speed. This is often referred to as the “backside of the power curve,” or flying “behind the power curve.” At these speeds, as pitch is increased to slow the gyroplane, more and more power is required to maintain level flight. At the point where maximum power available is being used, no further reduction in airspeed is possible without initiating a descent. This speed is referred to as the minimum level flight speed. Because there is no excess power available for acceleration, recovery from minimum level flight speed requires lowering the nose of the gyroplane and using altitude to regain airspeed. For this reason, it is essential to practice slow flight at altitudes that allow sufficient height for a safe recovery. Unintentionally flying a gyroplane on the backside of the power curve during approach and landing can be extremely

hazardous. Should a go-around become necessary, sufficient altitude to regain airspeed and initiate a climb may not be available, and ground contact may be unavoidable.

Flight at slow airspeeds is usually conducted at airspeeds 5 to 10 m.p.h. above the minimum level flight airspeed. When flying at slow airspeeds, it is important that your control inputs be smooth and slow to prevent a rapid loss of airspeed due to the high drag increases with small changes in pitch attitude. In addition, turns should be limited to shallow bank angles. In order to prevent losing altitude during turns, power must be added. Directional control remains very good while flying at slow airspeeds, because of the high velocity slipstream produced by the increased engine power.

Recovery to cruise flight speed is made by lowering the nose and increasing power. When the desired speed is reached, reduce power to the normal cruise power setting.

## COMMON ERRORS

1. Improper entry technique.
2. Failure to establish and maintain an appropriate airspeed.
3. Excessive variations of altitude and heading when a constant altitude and heading are specified.
4. Use of too steep a bank angle.
5. Rough or uncoordinated control technique.

## HIGH RATE OF DESCENT

A gyroplane will descend at a high rate when flown at very low forward airspeeds. This maneuver may be entered intentionally when a steep descent is desired, and can be performed with or without power. An unintentional high rate of descent can also occur as a result

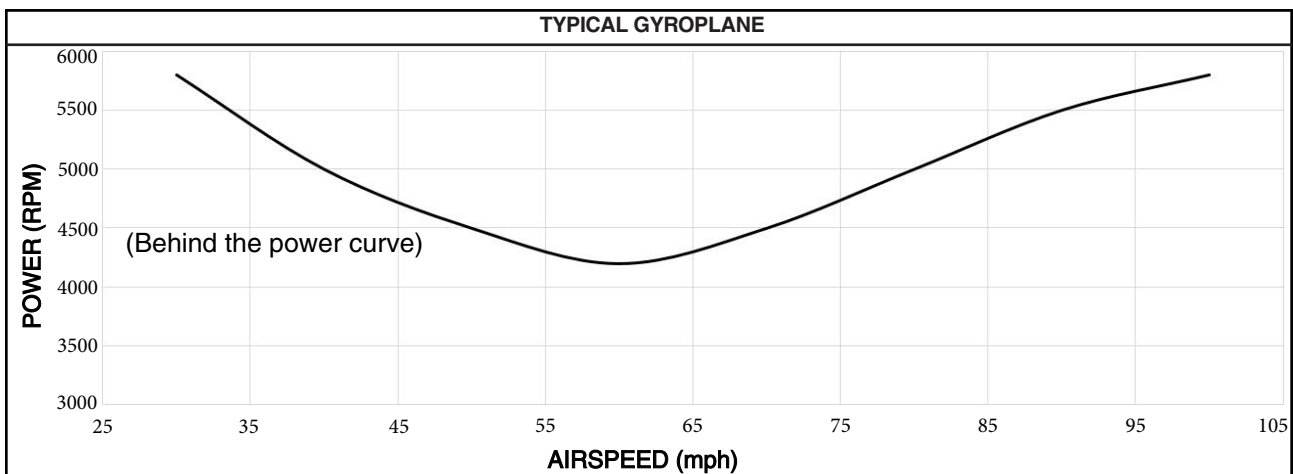


Figure 20-13. The low point on the power required curve is the speed that the gyroplane can fly while using the least amount of power, and is also the speed that will result in a minimum sink rate in a power-off glide.

of failing to monitor and maintain proper airspeed. In powered flight, if the gyroplane is flown below minimum level flight speed, a descent results even though full engine power is applied. Further reducing the airspeed with aft cyclic increases the rate of descent. For gyroplanes with a high thrust-to-weight ratio, this maneuver creates a very high pitch attitude. To recover, the nose of the gyroplane must be lowered slightly to exchange altitude for an increase in airspeed.

When operating a gyroplane in an unpowered glide, slowing to below the best glide speed can also result in a high rate of descent. As airspeed decreases, the rate of descent increases, reaching the highest rate as forward speed approaches zero. At slow airspeeds without the engine running, there is very little airflow over the tail surfaces and rudder effectiveness is greatly reduced. Rudder pedal inputs must be exaggerated to maintain effective yaw control. To recover, add power, if available, or lower the nose and allow the gyroplane to accelerate to the proper airspeed. This maneuver demonstrates the importance of maintaining the proper glide speed during an engine-out emergency landing. Attempting to stretch the glide by raising the nose results in a higher rate of descent at a lower forward speed, leaving less distance available for the selection of a landing site.

## COMMON ERRORS

1. Improper entry technique.
2. Failure to recognize a high rate of descent.
3. Improper use of controls during recovery.
4. Initiation of recovery below minimum recovery altitude.

## LANDINGS

Landings may be classified according to the landing surface, obstructions, and atmospheric conditions. Each type of landing assumes that certain conditions exist. To meet the actual conditions, a combination of techniques may be necessary.

### NORMAL LANDING

The procedure for a normal landing in a gyroplane is predicated on having a prepared landing surface and no significant obstructions in the immediate area. After entering a traffic pattern that conforms to established standards for the airport and avoids the flow of fixed wing traffic, a before landing checklist should be reviewed. The extent of the items on the checklist is dependent on the complexity of the gyroplane, and can include fuel, mixture, carburetor heat, propeller, engine instruments, and a check for traffic.

Gyroplanes experience a slight lag between control input and aircraft response. This lag becomes more

apparent during the sensitive maneuvering required for landing, and care must be taken to avoid overcorrecting for deviations from the desired approach path. After the turn to final, the approach airspeed appropriate for the gyroplane should be established. This speed is normally just below the minimum power required speed for the gyroplane in level flight. During the approach, maintain this airspeed by making adjustments to the gyroplane's pitch attitude, as necessary. Power is used to control the descent rate.

Approximately 10 to 20 feet above the runway, begin the flare by gradually increasing back pressure on the cyclic to reduce speed and decrease the rate of descent. The gyroplane should reach a near-zero rate of descent approximately 1 foot above the runway with the power at idle. Low airspeed combined with a minimum of propwash over the tail surfaces reduces rudder effectiveness during the flare. If a yaw moment is encountered, use whatever rudder control is required to maintain the desired heading. The gyroplane should be kept laterally level and with the longitudinal axis in the direction of ground track. Landing with sideward motion can damage the landing gear and must be avoided. In a full-flare landing, attempt to hold the gyroplane just off the runway by steadily increasing back pressure on the cyclic. This causes the gyroplane to settle slowly to the runway in a slightly nose-high attitude as forward momentum dissipates.

Ground roll for a full-flare landing is typically under 50 feet, and touchdown speed under 20 m.p.h. If a 20 m.p.h. or greater headwind exists, it may be necessary to decrease the length of the flare and allow the gyroplane to touch down at a slightly higher airspeed to prevent it from rolling backward on landing. After touchdown, rotor r.p.m. decays rather rapidly. On landings where brakes are required immediately after touchdown, apply them lightly, as the rotor is still carrying much of the weight of the aircraft and too much braking causes the tires to skid.

### SHORT-FIELD LANDING

A short-field landing is necessary when you have a relatively short landing area or when an approach must be made over obstacles that limit the available landing area. When practicing short-field landings, assume you are making the approach and landing over a 50-foot obstruction in the approach area.

To conduct a short-field approach and landing, follow normal procedures until you are established on the final approach segment. At this point, use aft cyclic to reduce airspeed below the speed for minimum sink. By decreasing speed, sink rate increases and a steeper approach path is achieved, minimizing the distance between clearing the obstacle and



making contact with the surface. [Figure 20-14] The approach speed must remain fast enough, however, to allow the flare to arrest the forward and vertical speed of the gyroplane. If the approach speed is too low, the remaining vertical momentum will result in a hard landing. On a short-field landing with a slight headwind, a touchdown with no ground roll is possible. Without wind, the ground roll is normally less than 50 feet.

### SOFT-FIELD LANDING

Use the soft-field landing technique when the landing surface presents high wheel drag, such as mud, snow, sand, tall grass or standing water. The objective is to transfer the weight of the gyroplane from the rotor to the landing gear as gently and slowly as possible. With a headwind close to the touchdown speed of the gyroplane, a power approach can be made close to the minimum level flight speed. As you increase the nose pitch attitude just prior to touchdown, add additional power to cushion the landing. However, power should be removed, just as the wheels are ready to touch. This results in a very slow, gentle touchdown. In a strong headwind, avoid allowing the gyroplane to roll rearward at touchdown. After touchdown, smoothly and gently lower the nosewheel to the ground. Minimize the use of brakes, and remain aware that the nosewheel could dig in the soft surface.

When no wind exists, use a steep approach similar to a short-field landing so that the forward speed can be dissipated during the flare. Use the throttle to cushion the touchdown.

### CROSSWIND LANDING

Crosswind landing technique is normally used in gyroplanes when a crosswind of approximately 15 m.p.h. or less exists. In conditions with higher crosswinds, it becomes very difficult, if not impossible, to maintain adequate compensation for the crosswind. In these conditions, the slow touchdown speed of a gyroplane allows a much safer option of turning directly into the wind and landing with little or no ground roll. Deciding when to use this technique, however, may be complicated by gusting winds or the characteristics of the particular landing area.

On final approach, establish a crab angle into the wind to maintain a ground track that is aligned with the extended centerline of the runway. Just before touchdown, remove the crab angle and bank the gyroplane slightly into the wind to prevent drift. Maintain longitudinal alignment with the runway using the rudder. In higher crosswinds, if full rudder deflection is not sufficient to maintain alignment with the runway, applying a slight amount of power can increase rudder effectiveness. The length of the flare should be reduced to allow a slightly higher touchdown speed than that used in a no-wind landing. Touchdown is made on the upwind main wheel first, with the other main wheel settling to the runway as forward momentum is lost. After landing, continue to keep the rotor tilted into the wind to maintain positive control during the rollout.

### HIGH-ALTITUDE LANDING

A high-altitude landing assumes a density altitude near the limit of what is considered good climb performance

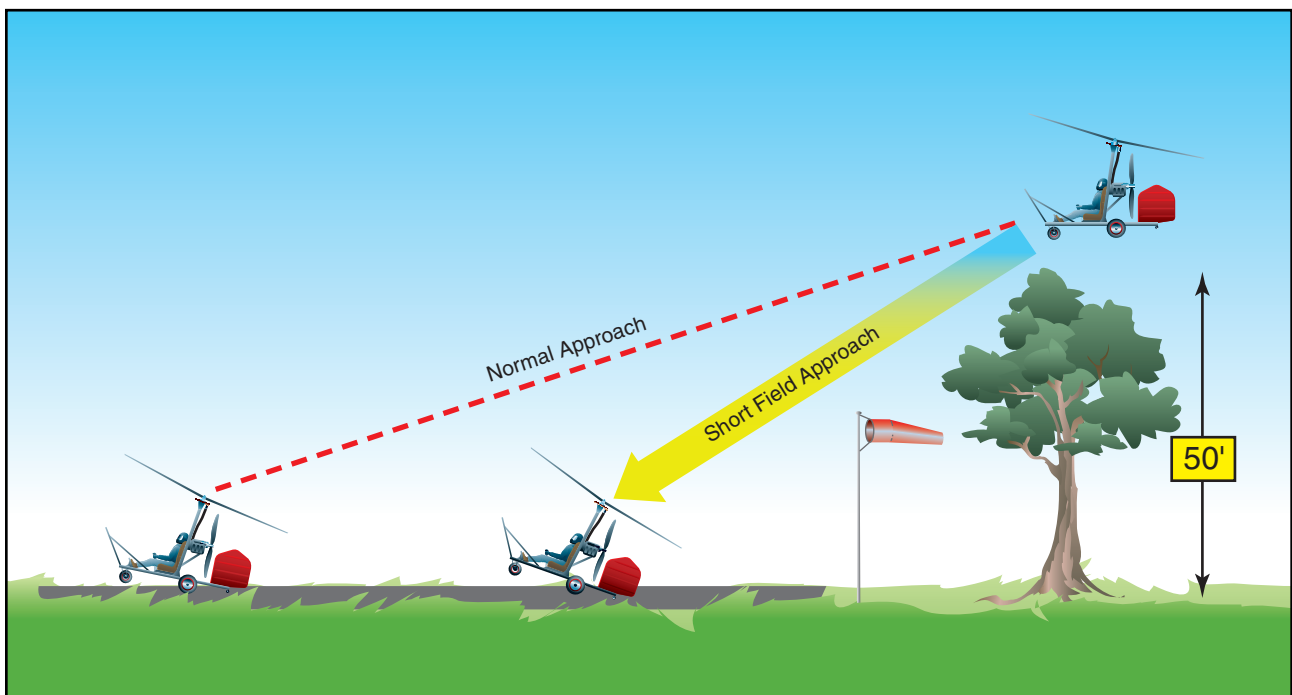


Figure 20-14. The airspeed used on a short-field approach is slower than that for a normal approach, allowing a steeper approach path and requiring less runway.

for the gyroplane. When using the same indicated airspeed as that used for a normal approach at lower altitude, a high density altitude results in higher rotor r.p.m. and a slightly higher rate of descent. The greater vertical velocity is a result of higher true airspeed as compared with that at low altitudes. When practicing high-altitude landings, it is prudent to first learn normal landings with a flare and roll out. Full flare, no roll landings should not be attempted until a good feel for aircraft response at higher altitudes has been acquired. As with high-altitude takeoffs, it is also important to consider the effects of higher altitude on engine performance.

### **COMMON ERRORS DURING LANDING**

1. Failure to establish and maintain a stabilized approach.
2. Improper technique in the use of power.
3. Improper technique during flare or touchdown.
4. Touchdown at too low an airspeed with strong headwinds, causing a rearward roll.
5. Poor directional control after touchdown.
6. Improper use of brakes.

### **GO-AROUND**

The go-around is used to abort a landing approach when unsafe factors for landing are recognized. If the decision is made early in the approach to go around, normal climb procedures utilizing  $V_X$  and  $V_Y$  should be used. A late decision to go around, such as after the full flare has been initiated, may result in an airspeed where power required is greater than power available. When this occurs, a touchdown becomes unavoidable and it may be safer to proceed with the landing than to sustain an extended ground roll that would be required

to go around. Also, the pitch attitude of the gyroplane in the flare is high enough that the tail would be considerably lower than the main gear, and a touch down with power on would result in a sudden pitch down and acceleration of the aircraft. Control of the gyroplane under these circumstances may be difficult. Consequently, the decision to go around should be made as early as possible, before the speed is reduced below the point that power required exceeds power available.

### **COMMON ERRORS**

1. Failure to recognize a situation where a go-around is necessary.
2. Improper application of power.
3. Failure to control pitch attitude.
4. Failure to maintain recommended airspeeds.
5. Failure to maintain proper track during climb out.

### **AFTER LANDING AND SECURING**

The after-landing checklist should include such items as the transponder, cowl flaps, fuel pumps, lights, and magneto checks, when so equipped. The rotor blades demand special consideration after landing, as turning rotor blades can be hazardous to others. Never enter an area where people or obstructions are present with the rotor turning. To assist the rotor in slowing, tilt the cyclic control into the prevailing wind or face the gyroplane downwind. When slowed to under approximately 75 r.p.m., the rotor brake may be applied, if available. Use caution as the rotor slows, as excess taxi speed or high winds could cause blade flap to occur. The blades should be depitched when taxiing if a collective control is available. When leaving the gyroplane, always secure the blades with a tiedown or rotor brake.

**Density Altitude**—Pressure altitude corrected for nonstandard temperature. This is a theoretical value that is used in determining aircraft performance.

# Gyroplane Emergencies

Gyroplanes are quite reliable, however emergencies do occur, whether a result of mechanical failure or pilot error. By having a thorough knowledge of the gyroplane and its systems, you will be able to more readily handle the situation. In addition, by knowing the conditions which can lead to an emergency, many potential accidents can be avoided.

## ABORTED TAKEOFF

Prior to every takeoff, consideration must be given to a course of action should the takeoff become undesirable or unsafe. Mechanical failures, obstructions on the takeoff surface, and changing weather conditions are all factors that could compromise the safety of a takeoff and constitute a reason to abort. The decision to abort a takeoff should be definitive and made as soon as an unsafe condition is recognized. By initiating the abort procedures early, more time and distance will be available to bring the gyroplane to a stop. A late decision to abort, or waiting to see if it will be necessary to abort, can result in a dangerous situation with little time to respond and very few options available.

When initiating the abort sequence prior to the gyroplane leaving the surface, the procedure is quite simple. Reduce the throttle to idle and allow the gyroplane to decelerate, while slowly applying aft cyclic for aerodynamic braking. This technique provides the most effective braking and slows the aircraft very quickly. If the gyroplane has left the surface when the decision to abort is made, reduce the throttle until an appropriate descent rate is achieved. Once contact with the surface is made, reduce the throttle to idle and apply aerodynamic braking as before. The wheel brakes, if the gyroplane is so equipped, may be applied, as necessary, to assist in slowing the aircraft.

## ACCELERATE/STOP DISTANCE

An accelerate/stop distance is the length of ground roll an aircraft would require to accelerate to takeoff speed and, assuming a decision to abort the takeoff is made, bring the aircraft safely to a stop. This value changes for a given aircraft based on atmospheric conditions, the takeoff surface, aircraft weight, and other factors affecting performance. Knowing the accelerate/stop value for your gyroplane can be helpful in planning a

safe takeoff, but having this distance available does not necessarily guarantee a safe aborted takeoff is possible for every situation. If the decision to abort is made after liftoff, for example, the gyroplane will require considerably more distance to stop than the accelerate/stop figure, which only considers the ground roll requirement. Planning a course of action for an abort decision at various stages of the takeoff is the best way to ensure the gyroplane can be brought safely to a stop should the need arise.

For a gyroplane without a flight manual or other published performance data, the accelerate/stop distance can be reasonably estimated once you are familiar with the performance and takeoff characteristics of the aircraft. For a more accurate figure, you can accelerate the gyroplane to takeoff speed, then slow to a stop, and note the distance used. Doing this several times gives you an average accelerate/stop distance. When performance charts for the aircraft are available, as in the flight manual of a certificated gyroplane, accurate accelerate/stop distances under various conditions can be determined by referring to the ground roll information contained in the charts.

## LIFT-OFF AT LOW AIRSPEED AND HIGH ANGLE OF ATTACK

Because of ground effect, your gyroplane might be able to become airborne at an airspeed less than minimum level flight speed. In this situation, the gyroplane is flying well behind the power curve and at such a high angle of attack that unless a correction is made, there will be little or no acceleration toward best climb speed. This condition is often encountered in gyroplanes capable of jump takeoffs. Jumping without sufficient rotor inertia to allow enough time to accelerate through minimum level flight speed, usually results in your gyroplane touching down after liftoff. If you do touch down after performing a jump takeoff, you should abort the takeoff.

During a rolling takeoff, if the gyroplane is forced into the air too early, you could get into the same situation. It is important to recognize this situation and take immediate corrective action. You can either abort the takeoff, if enough runway exists, or lower the nose and

accelerate to the best climb speed. If you choose to continue the takeoff, verify that full power is applied, then, slowly lower the nose, making sure the gyroplane does not contact the surface. While in ground effect, accelerate to the best climb speed. Then, adjust the nose pitch attitude to maintain that airspeed.

## COMMON ERRORS

The following errors might occur when practicing a lift-off at a low airspeed.

1. Failure to check rotor for proper operation, track, and r.p.m. prior to initiating takeoff.
2. Use of a power setting that does not simulate a “behind the power curve” situation.
3. Poor directional control.
4. Rotation at a speed that is inappropriate for the maneuver.
5. Poor judgement in determining whether to abort or continue takeoff.
6. Failure to establish and maintain proper climb attitude and airspeed, if takeoff is continued.
7. Not maintaining the desired ground track during the climb.

## PILOT-INDUCED OSCILLATION (PIO)

Pilot-induced oscillation, sometimes referred to as porpoising, is an unintentional up-and-down oscillation of the gyroplane accompanied with alternating climbs and descents of the aircraft. PIO is often the result of an inexperienced pilot overcontrolling the gyroplane, but this condition can also be induced by gusty wind conditions. While this condition is usually thought of as a longitudinal problem, it can also happen laterally.

As with most other rotor-wing aircraft, gyroplanes experience a slight delay between control input and the reaction of the aircraft. This delay may cause an inexperienced pilot to apply more control input than required, causing a greater aircraft response than was desired. Once the error has been recognized, opposite control input is applied to correct the flight attitude. Because of the nature of the delay in aircraft response, it is possible for the corrections to be out of synchronization with the movements of the aircraft and aggravate the undesired changes in attitude. The result is PIO, or unintentional oscillations that can grow rapidly in magnitude. [Figure 21-1]

In gyroplanes with an open cockpit and limited flight instruments, it can be difficult for an inexperienced pilot to recognize a level flight attitude due to the lack of visual references. As a result, PIO can develop as the pilot chases a level flight attitude and introduces climbing and descending oscillations. PIO can also develop if a wind gust displaces the aircraft, and the control inputs made to correct the attitude are out of phase with the aircraft movements. Because the rotor disc angle decreases at higher speeds and cyclic control becomes more sensitive, PIO is more likely to occur and can be more pronounced at high airspeeds. To minimize the possibility of PIO, avoid high-speed flight in gusty conditions, and make only small control inputs. After making a control input, wait briefly and observe the reaction of the aircraft before making another input. If PIO is encountered, reduce power and place the cyclic in the position for a normal climb. Once the oscillations have stopped, slowly return the throttle and cyclic to their normal positions. The likelihood of encountering PIO decreases greatly as experience is gained, and the ability to subconsciously anticipate the reactions of the gyroplane to control inputs is developed.

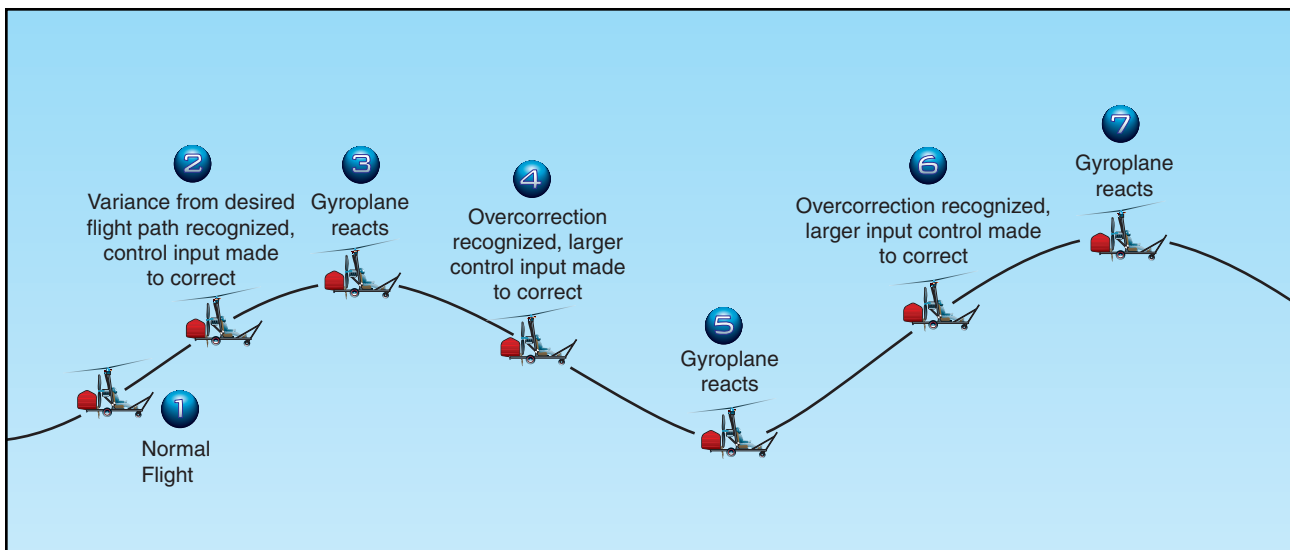


Figure 21-1. Pilot-induced oscillation can result if the gyroplane’s reactions to control inputs are not anticipated and become out of phase.



## BUNTOVER (POWER PUSHOVER)

As you learned in Chapter 16—Gyroplane Aerodynamics, the stability of a gyroplane is greatly influenced by rotor force. If rotor force is rapidly removed, some gyroplanes have a tendency to pitch forward abruptly. This is often referred to as a forward tumble, buntover, or power pushover. Removing the rotor force is often referred to as unloading the rotor, and can occur if pilot-induced oscillations become excessive, if extremely turbulent conditions are encountered, or the nose of the gyroplane is pushed forward rapidly after a steep climb.

A power pushover can occur on some gyroplanes that have the propeller thrust line above the center of gravity and do not have an adequate horizontal stabilizer. In this case, when the rotor is unloaded, the propeller thrust magnifies the pitching moment around the center of gravity. Unless a correction is made, this nose pitching action could become self-sustaining and irreversible. An adequate horizontal stabilizer slows the pitching rate and allows time for recovery.

Since there is some disagreement between manufacturers as to the proper recovery procedure for this situation, you must check with the manufacturer of your gyroplane. In most cases, you need to remove power and load the rotor blades. Some manufacturers, especially those with gyroplanes where the propeller thrust line is above the center of gravity, recommend that you need to immediately remove power in order to prevent a power pushover situation. Other manufacturers recommend that you first try to load the rotor blades. For the proper positioning of the cyclic when loading up the rotor blades, check with the manufacturer.

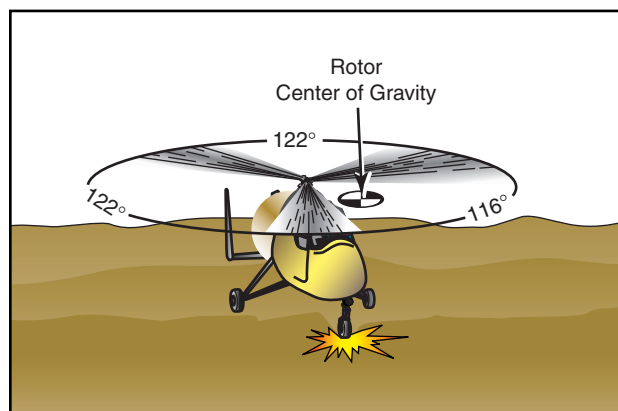
When compared to other aircraft, the gyroplane is just as safe and very reliable. The most important factor, as in all aircraft, is pilot proficiency. Proper training and flight experience helps prevent the risks associated with pilot-induced oscillation or buntover.

## GROUND RESONANCE

Ground resonance is a potentially damaging aerodynamic phenomenon associated with articulated rotor systems. It develops when the rotor blades move out of phase with each other and cause the rotor disc to become unbalanced. If not corrected, ground resonance can cause serious damage in a matter of seconds.

Ground resonance can only occur while the gyroplane is on the ground. If a shock is transmitted to the rotor system, such as with a hard landing on one gear or when operating on rough terrain, one or more of the blades could lag or lead and allow the rotor system's center of gravity to be displaced from the center of rotation. Subsequent shocks to the other gear aggravate the

imbalance causing the rotor center of gravity to rotate around the hub. This phenomenon is not unlike an out-of-balance washing machine. [Figure 21-2]



**Figure 21-2. Taxiing on rough terrain can send a shock wave to the rotor system, resulting in the blades of a three-bladed rotor system moving from their normal 120° relationship to each other.**

To reduce the chance of experiencing ground resonance, every preflight should include a check for proper strut inflation, tire pressure, and lag-lead damper operation. Improper strut or tire inflation can change the vibration frequency of the airframe, while improper damper settings change the vibration frequency of the rotor.

If you experience ground resonance, and the rotor r.p.m. is not yet sufficient for flight, apply the rotor brake to maximum and stop the rotor as soon as possible. If ground resonance occurs during takeoff, when rotor r.p.m. is sufficient for flight, lift off immediately. Ground resonance cannot occur in flight, and the rotor blades will automatically realign themselves once the gyroplane is airborne. When prerotating the rotor system prior to takeoff, a slight vibration may be felt that is a very mild form of ground resonance. Should this oscillation amplify, discontinue the prerotation and apply maximum rotor brake.

## EMERGENCY APPROACH AND LANDING

The modern engines used for powering gyroplanes are generally very reliable, and an actual mechanical malfunction forcing a landing is not a common occurrence. Failures are possible, which necessitates planning for and practicing emergency approaches and landings. The best way to ensure that important items are not overlooked during an emergency procedure is to use a checklist, if one is available and time permits. Most gyroplanes do not have complex electrical, hydraulic, or pneumatic systems that require lengthy checklists. In these aircraft, the checklist can be easily committed to memory so that immediate action can be taken if

needed. In addition, you should always maintain an awareness of your surroundings and be constantly on the alert for suitable emergency landing sites.

When an engine failure occurs at altitude, the first course of action is to adjust the gyroplane's pitch attitude to achieve the best glide speed. This yields the most distance available for a given altitude, which in turn, allows for more possible landing sites. A common mistake when learning emergency procedures is attempting to stretch the glide by raising the nose, which instead results in a steep approach path at a slow airspeed and a high rate of descent. [Figure 21-3] Once you have attained best glide speed, scan the area within gliding distance for a suitable landing site. Remember to look behind the aircraft, as well as in front, making gentle turns, if necessary, to see around the airframe. When selecting a landing site, you must consider the wind direction and speed, the size of the landing site, obstructions to the approach, and the condition of the surface. A site that allows a landing into the wind and has a firm, smooth surface with no obstructions is the most desirable. When considering landing on a road, be alert for powerlines, signs, and automobile traffic. In many cases, an ideal site will not be available, and it will be necessary for you to evaluate your options and choose the best alternative. For example, if a steady wind will allow a touchdown with no ground roll, it may be acceptable to land in a softer field or in a

smaller area than would normally be considered. On landing, use short or soft field technique, as appropriate, for the site selected. A slightly higher-than-normal approach airspeed may be required to maintain adequate airflow over the rudder for proper yaw control.

## EMERGENCY EQUIPMENT AND SURVIVAL GEAR

On any flight not in the vicinity of an airport, it is highly advisable to prepare a survival kit with items that would be necessary in the event of an emergency. A properly equipped survival kit should be able to provide you with sustenance, shelter, medical care, and a means to summon help without a great deal of effort on your part. An efficient way to organize your survival kit is to prepare a basic core of supplies that would be necessary for any emergency, and allow additional space for supplementary items appropriate for the terrain and weather you expect for a particular flight. The basic items to form the basis of your survival kit would typically include: a first-aid kit and field medical guide, a flashlight, water, a knife, matches, some type of shelter, and a signaling device. Additional items that may be added to meet the conditions, for example, would be a lifevest for a flight over water, or heavy clothing for a flight into cold weather. Another consideration is carrying a cellular phone. Several pilots have been rescued after calling someone to indicate there had been an accident.

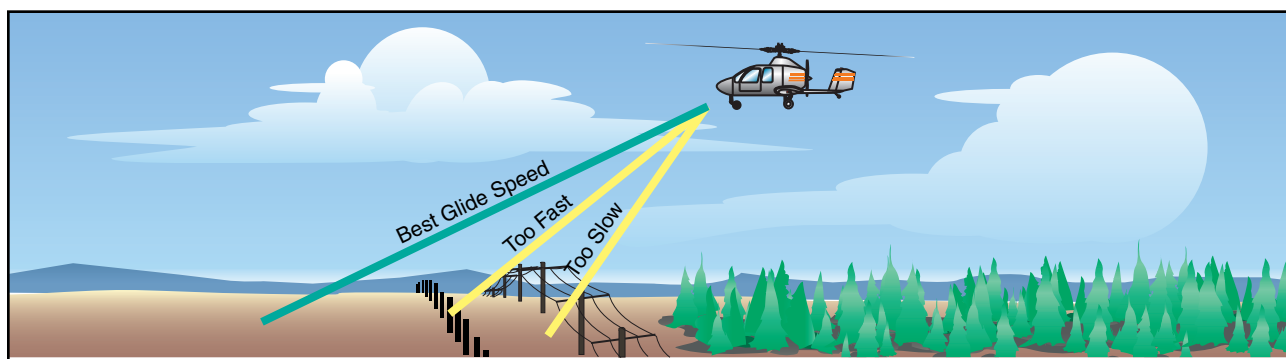


Figure 21-3. Any deviation from best glide speed will reduce the distance you can glide and may cause you to land short of a safe touchdown point.

## Aeronautical Decision Making

As with any aircraft, the ability to pilot a gyroplane safely is largely dependent on the capacity of the pilot to make sound and informed decisions. To this end, techniques have been developed to ensure that a pilot uses a systematic approach to making decisions, and that the course of action selected is the most appropriate for the situation. In addition, it is essential that you learn to evaluate your own fitness, just as you evaluate the airworthiness of your aircraft, to ensure that your physical and mental condition is compatible with a safe flight. The techniques for acquiring these essential skills are explained in depth in Chapter 14—Aeronautical Decision Making (Helicopter).

As explained in Chapter 14, one of the best methods to develop your aeronautical decision making is learning to recognize the five hazardous attitudes, and how to counteract these attitudes. [Figure 22-1] This chapter focuses on some examples of how these hazardous attitudes can apply to gyroplane operations.

HAZARDOUS ATTITUDE	ANTIDOTE
<b>Impulsivity:</b> "Do something—quickly!"	"Not so fast. Think first."
<b>Invulnerability:</b> "It won't happen to me!"	"It could happen to me."
<b>Macho:</b> "I can do it."	"Taking chances is foolish."
<b>Resignation:</b> "What's the use?"	"I'm not helpless. I can make the difference."
<b>Anti-authority:</b> "Don't tell me!"	"Follow the rules. They are usually right."

**Figure 22-1. To overcome hazardous attitudes, you must memorize the antidotes for each of them. You should know them so well that they will automatically come to mind when you need them.**

### IMPULSIVITY

Gyroplanes are a class of aircraft which can be acquired, constructed, and operated in ways unlike most other aircraft. This inspires some of the most exciting and rewarding aspects of flying, but it also creates a unique set of dangers to which a gyroplane pilot must be alert. For example, a wide variety of amateur-built gyroplanes are available, which can be purchased in kit form and

assembled at home. This makes the airworthiness of these gyroplanes ultimately dependent on the vigilance of the one assembling and maintaining the aircraft. Consider the following scenario.

*Jerry recently attended an airshow that had a gyroplane flight demonstration and a number of gyroplanes on display. Being somewhat mechanically inclined and retired with available spare time, Jerry decided that building a gyroplane would be an excellent project for him and ordered a kit that day. When the kit arrived, Jerry unpacked it in his garage and immediately began the assembly. As the gyroplane neared completion, Jerry grew more excited at the prospect of flying an aircraft that he had built with his own hands. When the gyroplane was nearly complete, Jerry noticed that a rudder cable was missing from the kit, or perhaps lost during the assembly. Rather than contacting the manufacturer and ordering a replacement, which Jerry thought would be a hassle and too time consuming, he went to his local hardware store and purchased some cable he thought would work. Upon returning home, he was able to fashion a rudder cable that seemed functional and continued with the assembly.*

Jerry is exhibiting “impulsivity.” Rather than taking the time to properly build his gyroplane to the specifications set forth by the manufacturer, Jerry let his excitement allow him to cut corners by acting on impulse, rather than taking the time to think the matter through. Although some enthusiasm is normal during assembly, it should not be permitted to compromise the airworthiness of the aircraft. Manufacturers often use high quality components, which are constructed and tested to standards much higher than those found in hardware stores. This is particularly true in the area of cables, bolts, nuts, and other types of fasteners where strength is essential. The proper course of action Jerry should have taken would be to stop, think, and consider the possible consequences of making an impulsive decision. Had he realized that a broken rudder cable in flight could cause a loss of control of the gyroplane, he likely would have taken the time to contact the manufacturer and order a cable that met the design specifications.

### INVULNERABILITY

Another area that can often lead to trouble for a gyroplane pilots is the failure to obtain adequate flight

instruction to operate their gyroplane safely. This can be the result of people thinking that because they can build the machine themselves, it must be simple enough to learn how to fly by themselves. Other reasons that can lead to this problem can be simply monetary, in not wanting to pay the money for adequate instruction, or feeling that because they are qualified in another type of aircraft, flight instruction is not necessary. In reality, gyroplane operations are quite unique, and there is no substitute for adequate training by a competent and authorized instructor. Consider the following scenario.

*Jim recently met a coworker who is a certified pilot and owner of a two-seat gyroplane. In discussing the gyroplane with his coworker, Jim was fascinated and reminded of his days in the military as a helicopter pilot many years earlier. When offered a ride, Jim readily accepted. He met his coworker at the airport the following weekend for a short flight and was immediately hooked. After spending several weeks researching available designs, Jim decided on a particular gyroplane and purchased a kit. He had it assembled in a few months, with the help and advice of his new friend and fellow gyroplane enthusiast. When the gyroplane was finally finished, Jim asked his friend to take him for a ride in his two-seater to teach him the basics of flying. The next day, he said, he would figure out while flying his own machine from a landing strip that he had fashioned in a field behind his house.*

Jim is unknowingly inviting disaster by allowing himself to be influenced by the hazardous attitude of “invulnerability.” Jim does not feel that it is possible to have an accident, probably because of his past experience in helicopters and from witnessing the ease with which his coworker controlled the gyroplane on their flight together. What Jim is failing to consider, however, is the amount of time that has passed since he was proficient in helicopters, and the significant differences between helicopter and gyroplane operations. He is also overlooking the fact that his friend is a certificated pilot, who has taken a considerable amount of instruction to reach his level of competence. Without adequate instruction and experience, Jim could, for example, find himself in a pilot-induced oscillation without knowing the proper technique for recovery, which could ultimately be disastrous. The antidote for an attitude of invulnerability is to realize that accidents can happen to anyone.

## **MACHO**

Due to their unique design, gyroplanes are quite responsive and have distinct capabilities. Although gyroplanes are capable of incredible maneuvers, they do have limitations. As gyroplane pilots grow more comfortable with their machines, they might be

tempted to operate progressively closer to the edge of the safe operating envelope. Consider the following scenario.

*Pat has been flying gyroplanes for years and has an excellent reputation as a skilled pilot. He has recently built a high performance gyroplane with an advanced rotor system. Pat was excited to move into a more advanced aircraft because he had seen the same design performing aerobatics in an airshow earlier that year. He was amazed by the capability of the machine. He had always felt that his ability surpassed the capability of the aircraft he was flying. He had invested a large amount of time and resources into the construction of the aircraft, and, as he neared completion of the assembly, he was excited about the opportunity of showing his friends and family his capabilities.*

*During the first few flights, Pat was not completely comfortable in the new aircraft, but he felt that he was progressing through the transition at a much faster pace than the average pilot. One morning, when he was with some of his fellow gyroplane enthusiasts, Pat began to brag about the superior handling qualities of the machine he had built. His friends were very excited, and Pat realized that they would be expecting quite a show on his next flight. Not wanting to disappoint them, he decided that although it might be early, he would give the spectators on the ground a real show. On his first pass he came down fairly steep and fast and recovered from the dive with ease. Pat then decided to make another pass only this time he would come in much steeper. As he began to recover, the aircraft did not climb as he expected and almost settled to the ground. Pat narrowly escaped hitting the spectators as he was trying to recover from the dive.*

Pat had let the “macho” hazardous attitude influence his decision making. He could have avoided the consequences of this attitude if he had stopped to think that taking chances is foolish.

## **RESIGNATION**

Some of the elements pilots face cannot be controlled. Although we cannot control the weather, we do have some very good tools to help predict what it will do, and how it can affect our ability to fly safely. Good pilots always make decisions that will keep their options open if an unexpected event occurs while flying. One of the greatest resources we have in the cockpit is the ability to improvise and improve the overall situation even when a risk element jeopardizes the probability of a successful flight. Consider the following scenario.

*Judi flies her gyroplane out of a small grass strip on her family’s ranch. Although the rugged landscape of the ranch lends itself to the remarkable scenery, it*



*leaves few places to safely land in the event of an emergency. The only suitable place to land other than the grass strip is to the west on a smooth section of the road leading to the house. During Judi's training, her traffic patterns were always made with left turns. Figuring this was how she was to make all traffic patterns, she applied this to the grass strip at the ranch. In addition, she was uncomfortable with making turns to the right. Since, the wind at the ranch was predominately from the south, this meant that the traffic pattern was to the east of the strip.*

Judi's hazardous attitude is "resignation." She has accepted the fact that her only course of action is to fly east of the strip, and if an emergency happens, there is not much she can do about it. The antidote to this hazardous attitude is "I'm not helpless, I can make a difference." Judi could easily modify her traffic pattern so that she is always within gliding distance of a suitable landing area. In addition, if she was uncomfortable with a maneuver, she could get additional training.

## **ANTI-AUTHORITY**

Regulations are implemented to protect aviation personnel as well as the people who are not involved in aviation. Pilots who choose to operate outside of the

regulations, or on the ragged edge, eventually get caught, or even worse, they end up having an accident. Consider the following scenario.

*Dick is planning to fly the following morning and realizes that his medical certificate has expired. He knows that he will not have time to take a flight physical before his morning flight. Dick thinks to himself "The rules are too restrictive. Why should I spend the time and money on a physical when I will be the only one at risk if I fly tomorrow?"*

*Dick decides to fly the next morning thinking that no harm will come as long as no one finds out that he is flying illegally. He pulls his gyroplane out from the hangar, does the preflight inspection, and is getting ready to start the engine when an FAA inspector walks up and greets him. The FAA inspector is conducting a random inspection and asks to see Dick's pilot and medical certificates.*

Dick subjected himself to the hazardous attitude of "anti-authority." Now, he will be unable to fly, and has invited an exhaustive review of his operation by the FAA. Dick could have prevented this event if had taken the time to think, "Follow the rules. They are usually right."

This handbook was compiled by Ron Menzie and Bill Hogue from FAA document FAA-H-8083-21

# GLOSSARY

**ABSOLUTE ALTITUDE**—The actual distance an object is above the ground.

**ADVANCING BLADE**—The blade moving in the same direction as the helicopter or gyroplane. In rotorcraft that have counterclockwise main rotor blade rotation as viewed from above, the advancing blade is in the right half of the rotor disc area during forward movement.

**AIRFOIL**—Any surface designed to obtain a useful reaction of lift, or negative lift, as it moves through the air.

**AGONIC LINE**—A line along which there is no magnetic variation.

**AIR DENSITY**—The density of the air in terms of mass per unit volume. Dense air has more molecules per unit volume than less dense air. The density of air decreases with altitude above the surface of the earth and with increasing temperature.

**AIRCRAFT PITCH**—When referenced to an aircraft, it is the movement about its lateral, or pitch axis. Movement of the cyclic forward or aft causes the nose of the helicopter or gyroplane to pitch up or down.

**AIRCRAFT ROLL**—Is the movement of the aircraft about its longitudinal axis. Movement of the cyclic right or left causes the helicopter or gyroplane to tilt in that direction.

**AIRWORTHINESS DIRECTIVE**—When an unsafe condition exists with an aircraft, the FAA issues an airworthiness directive to notify concerned parties of the condition and to describe the appropriate corrective action.

**ALTIMETER**—An instrument that indicates flight altitude by sensing pressure changes and displaying altitude in feet or meters.

**ANGLE OF ATTACK**—The angle between the airfoil's chord line and the relative wind.

**ANTITORQUE PEDAL**—The pedal used to control the pitch of the tail rotor or air diffuser in a NOTAR® system.

**ANTITORQUE ROTOR**—See tail rotor.

**ARTICULATED ROTOR**—A rotor system in which each of the blades is connected to the rotor hub in such a way that it is free to change its pitch angle, and move up and down and fore and aft in its plane of rotation.

**AUTOPILOT**—Those units and components that furnish a means of automatically controlling the aircraft.

**AUTOROTATION**—The condition of flight during which the main rotor is driven only by aerodynamic forces with no power from the engine.

**AXIS-OF-ROTATION**—The imaginary line about which the rotor rotates. It is represented by a line drawn through the center of, and perpendicular to, the tip-path plane.

**BASIC EMPTY WEIGHT**—The weight of the standard rotorcraft, operational equipment, unusable fuel, and full operating fluids, including full engine oil.

**BLADE CONING**—An upward sweep of rotor blades as a result of lift and centrifugal force.

**BLADE DAMPER**—A device attached to the drag hinge to restrain the fore and aft movement of the rotor blade.

**BLADE FEATHER OR FEATHERING**—The rotation of the blade around the spanwise (pitch change) axis.

**BLADE FLAP**—The ability of the rotor blade to move in a vertical direction. Blades may flap independently or in unison.

**BLADE GRIP**—The part of the hub assembly to which the rotor blades are attached, sometimes referred to as blade forks.

**BLADE LEAD OR LAG**—The fore and aft movement of the blade in the plane of rotation. It is sometimes called hunting or dragging.

**BLADE LOADING**—The load imposed on rotor blades, determined by dividing the total weight of the helicopter by the combined area of all the rotor blades.

**BLADE ROOT**—The part of the blade that attaches to the blade grip.

**BLADE SPAN**—The length of a blade from its tip to its root.

**BLADE STALL**—The condition of the rotor blade when it is operating at an angle of attack greater than the maximum angle of lift.

**BLADE TIP**—The further most part of the blade from the hub of the rotor.

**BLADE TRACK**—The relationship of the blade tips in the plane of rotation. Blades that are in track will move through the same plane of rotation.

**BLADE TRACKING**—The mechanical procedure used to bring the blades of the rotor into a satisfactory relationship with each other under dynamic conditions so that all blades rotate on a common plane.

**BLADE TWIST**—The variation in the angle of incidence of a blade between the root and the tip.

**BLOWBACK**—The tendency of the rotor disc to tilt aft in forward flight as a result of flapping.

**BUNTOVER**—The tendency of a gyroplane to pitch forward when rotor force is removed.

**CALIBRATED AIRSPEED (CAS)**—Indicated airspeed of an aircraft, corrected for installation and instrumentation errors.

**CENTER OF GRAVITY**—The theoretical point where the entire weight of the helicopter is considered to be concentrated.

**CENTER OF PRESSURE**—The point where the resultant of all the aerodynamic forces acting on an airfoil intersects the chord.

**CENTRIFUGAL FORCE**—The apparent force that an object moving along a circular path exerts on the body constraining the object and that acts outwardly away from the center of rotation.

**CENTRIPETAL FORCE**—The force that attracts a body toward its axis of rotation. It is opposite centrifugal force.

**CHIP DETECTOR**—A warning device that alerts you to any abnormal wear in a transmission or engine. It consists of a magnetic plug located within the transmission. The magnet attracts any metal particles that have come loose from the bearings or other transmission parts. Most chip detectors have warning lights located on the instrument panel that illuminate when metal particles are picked up.

**CHORD**—An imaginary straight line between the leading and trailing edges of an airfoil section.

**CHORDWISE AXIS**—A term used in reference to semirigid rotors describing the flapping or teetering axis of the rotor.

**COAXIAL ROTOR**—A rotor system utilizing two rotors turning in opposite directions on the same centerline. This system is used to eliminate the need for a tail rotor.

**COLLECTIVE PITCH CONTROL**—The control for changing the pitch of all the rotor blades in the main rotor system equally and simultaneously and, consequently, the amount of lift or thrust being generated.

**CONING**—See blade coning.

**CORIOLIS EFFECT**—The tendency of a rotor blade to increase or decrease its velocity in its plane of rotation when the center of mass moves closer or further from the axis of rotation.

**CYCLIC FEATHERING**—The mechanical change of the angle of incidence, or pitch, of individual rotor blades independently of other blades in the system.

**CYCLIC PITCH CONTROL**—The control for changing the pitch of each rotor blade individually as it rotates through one cycle to govern the tilt of the rotor disc and, consequently, the direction and velocity of horizontal movement.

**DELTA HINGE**—A flapping hinge with a skewed axis so that the flapping motion introduces a component of feathering that would result in a restoring force in the flap-wise direction.

**DENSITY ALTITUDE**—Pressure altitude corrected for nonstandard temperature variations.

**DEVIATION**—A compass error caused by magnetic disturbances from the electrical and metal components in the aircraft. The correction for this error is displayed on a compass correction card placed near the magnetic compass of the aircraft.

**DIRECT CONTROL**—The ability to maneuver a rotorcraft by tilting the rotor disc and changing the pitch of the rotor blades.

**DIRECT SHAFT TURBINE**—A shaft turbine engine in which the compressor and power section are mounted on a common driveshaft.

**DISC AREA**—The area swept by the blades of the rotor. It is a circle with its center at the hub and has a radius of one blade length.

**DISC LOADING**—The total helicopter weight divided by the rotor disc area.

**DISSYMMETRY OF LIFT**—The unequal lift across the rotor disc resulting from the difference in the velocity of air over the advancing blade half and retreating blade half of the rotor disc area.

**DRAG**—An aerodynamic force on a body acting parallel and opposite to relative wind.

**DUAL ROTOR**—A rotor system utilizing two main rotors.

**DYNAMIC ROLLOVER**—The tendency of a helicopter to continue rolling when the critical angle is exceeded, if one gear is on the ground, and the helicopter is pivoting around that point.

**FEATHERING**—The action that changes the pitch angle of the rotor blades by rotating them around their feathering (spanwise) axis.

**FEATHERING AXIS**—The axis about which the pitch angle of a rotor blade is varied. Sometimes referred to as the spanwise axis.

**FEEDBACK**—The transmittal of forces, which are initiated by aerodynamic action on rotor blades, to the cockpit controls.

**FLAPPING HINGE**—The hinge that permits the rotor blade to flap and thus balance the lift generated by the advancing and retreating blades.

**FLAPPING**—The vertical movement of a blade about a flapping hinge.

**FLARE**—A maneuver accomplished prior to landing to slow down a rotorcraft.

**FREE TURBINE**—A turboshaft engine with no physical connection between the compressor and power output shaft.

**FREEWHEELING UNIT**—A component of the transmission or power train that automatically disconnects the main rotor from the engine when the engine stops or slows below the equivalent rotor r.p.m.

**FULLY ARTICULATED ROTOR SYSTEM**—See articulated rotor system.

**GRAVITY**—See weight.

**GROSS WEIGHT**—The sum of the basic empty weight and useful load.

**GROUND EFFECT**—A usually beneficial influence on rotorcraft performance that occurs while flying close to the ground. It results from a reduction in upwash, downwash, and bladetip vortices, which provide a corresponding decrease in induced drag.

**GROUND RESONANCE**—Self-excited vibration occurring whenever the frequency of oscillation of the blades about the lead-lag axis of an articulated rotor becomes the same as the natural frequency of the fuselage.

**GYROCOPTER**—Trademark applied to gyroplanes designed and produced by the Bensen Aircraft Company.

**GYROSCOPIC PRECESSION**—An inherent quality of rotating bodies, which causes an applied force to be manifested 90° in the direction of rotation from the point where the force is applied.

**HUMAN FACTORS**—The study of how people interact with their environment. In the case of general aviation, it is the study of how pilot performance is influenced by such issues as the design of cockpits, the function of the organs of the body, the effects of emotions, and the interac-

tion and communication with other participants in the aviation community, such as other crew members and air traffic control personnel.

**HUNTING**—Movement of a blade with respect to the other blades in the plane of rotation, sometimes called leading or lagging.

**INERTIA**—The property of matter by which it will remain at rest or in a state of uniform motion in the same direction unless acted upon by some external force.

**IN GROUND EFFECT (IGE) HOVER**—Hovering close to the surface (usually less than one rotor diameter distance above the surface) under the influence of ground effect.

**INDUCED DRAG**—That part of the total drag that is created by the production of lift.

**INDUCED FLOW**—The component of air flowing vertically through the rotor system resulting from the production of lift.

**ISOGONIC LINES**—Lines on charts that connect points of equal magnetic variation.

**KNOT**—A unit of speed equal to one nautical mile per hour.

**L/D<sub>MAX</sub>**—The maximum ratio between total lift (L) and total drag (D). This point provides the best glide speed. Any deviation from the best glide speed increases drag and reduces the distance you can glide.

**LATERAL VIBRATION**—A vibration in which the movement is in a lateral direction, such as imbalance of the main rotor.

**LEAD AND LAG**—The fore (lead) and aft (lag) movement of the rotor blade in the plane of rotation.

**LICENSED EMPTY WEIGHT**—Basic empty weight not including full engine oil, just undrainable oil.

**LIFT**—One of the four main forces acting on a rotorcraft. It acts perpendicular to the relative wind.

**LOAD FACTOR**—The ratio of a specified load to the total weight of the aircraft.

**MARRIED NEEDLES**—A term used when two hands of an instrument are superimposed over each other, as on the engine/rotor tachometer.

**MAST**—The component that supports the main rotor.

**MAST BUMPING**—Action of the rotor head striking the mast, occurring on underslung rotors only.

**MINIMUM LEVEL FLIGHT SPEED**—The speed below which a gyroplane, the propeller of which is producing maximum thrust, loses altitude.

**NAVIGATIONAL AID (NAVAID)**—Any visual or electronic device, airborne or on the surface, that provides point-to-point guidance information, or position data, to aircraft in flight.

**NIGHT**—The time between the end of evening civil twilight and the beginning of morning civil twilight, as published in the American Air Almanac.

**NORMALLY ASPIRATED ENGINE**—An engine that does not compensate for decreases in atmospheric pressure through turbocharging or other means.

**ONE-TO-ONE VIBRATION**—A low frequency vibration having one beat per revolution of the rotor. This vibration can be either lateral, vertical, or horizontal.

**OUT OF GROUND EFFECT (OGE) HOVER**—Hovering greater than one diameter distance above the surface. Because induced drag is greater while hovering out of ground effect, it takes more power to achieve a hover out of ground effect.



**PARASITE DRAG**—The part of total drag created by the form or shape of helicopter parts.

**PAYLOAD**—The term used for passengers, baggage, and cargo.

**PENDULAR ACTION**—The lateral or longitudinal oscillation of the fuselage due to it being suspended from the rotor system.

**PITCH ANGLE**—The angle between the chord line of the rotor blade and the reference plane of the main rotor hub or the rotor plane of rotation.

**PREROTATION**—In a gyroplane, it is the spinning of the rotor to a sufficient r.p.m. prior to flight.

**PRESSURE ALTITUDE**—The height above the standard pressure level of 29.92 in. Hg. It is obtained by setting 29.92 in the barometric pressure window and reading the altimeter.

**PROFILE DRAG**—Drag incurred from frictional or parasitic resistance of the blades passing through the air. It does not change significantly with the angle of attack of the airfoil section, but it increases moderately as airspeed increases.

**RESULTANT RELATIVE WIND**—Airflow from rotation that is modified by induced flow.

**RETREATING BLADE**—Any blade, located in a semicircular part of the rotor disc, where the blade direction is opposite to the direction of flight.

**RETREATING BLADE STALL**—A stall that begins at or near the tip of a blade in a helicopter because of the high angles of attack required to compensate for dissymmetry of lift. In a gyroplane the stall occurs at 20 to 40 percent outboard from the hub.

**RIGID ROTOR**—A rotor system permitting blades to feather but not flap or hunt.

**ROTATIONAL VELOCITY**—The component of relative wind produced by the rotation of the rotor blades.

**ROTOR**—A complete system of rotating airfoils creating lift for a helicopter or gyroplane.

**ROTOR DISC AREA**—See disk area.

**ROTOR BRAKE**—A device used to stop the rotor blades during shutdown.

**ROTOR FORCE**—The force produced by the rotor in a gyroplane. It is comprised of rotor lift and rotor drag.

**SEMIRIGID ROTOR**—A rotor system in which the blades are fixed to the hub but are free to flap and feather.

**SETTLING WITH POWER**—See vortex ring state.

**SHAFT TURBINE**—A turbine engine used to drive an output shaft commonly used in helicopters.

**SKID**—A flight condition in which the rate of turn is too great for the angle of bank.

**SKID SHOES**—Plates attached to the bottom of skid landing gear protecting the skid.

**SLIP**—A flight condition in which the rate of turn is too slow for the angle of bank.

**SOLIDITY RATIO**—The ratio of the total rotor blade area to total rotor disc area.

**SPAN**—The dimension of a rotor blade or airfoil from root to tip.

**SPLIT NEEDLES**—A term used to describe the position of the two needles on the engine/rotor tachometer when the two needles are not superimposed.

**STANDARD ATMOSPHERE**—A hypothetical atmosphere based on averages in which the surface temperature is 59°F (15°C), the surface pressure is 29.92 in. Hg (1013.2 Mb) at sea level, and the temperature lapse rate is approximately 3.5°F (2°C) per 1,000 feet.

**STATIC STOP**—A device used to limit the blade flap, or rotor flap, at low r.p.m. or when the rotor is stopped.

**STEADY-STATE FLIGHT**—A condition when a rotorcraft is in straight-and-level, unaccelerated flight, and all forces are in balance.

**SYMMETRICAL AIRFOIL**—An airfoil having the same shape on the top and bottom.

**TAIL ROTOR**—A rotor turning in a plane perpendicular to that of the main rotor and parallel to the longitudinal axis of the fuselage. It is used to control the torque of the main rotor and to provide movement about the yaw axis of the helicopter.

**TEETERING HINGE**—A hinge that permits the rotor blades of a semirigid rotor system to flap as a unit.

**THRUST**—The force developed by the rotor blades acting parallel to the relative wind and opposing the forces of drag and weight.

**TIP-PATH PLANE**—The imaginary circular plane outlined by the rotor blade tips as they make a cycle of rotation.

**TORQUE**—In helicopters with a single, main rotor system, the tendency of the helicopter to turn in the opposite direction of the main rotor rotation.

**TRAILING EDGE**—The rearmost edge of an airfoil.

**TRANSLATING TENDENCY**—The tendency of the single-rotor helicopter to move laterally during hovering flight. Also called tail rotor drift.

**TRANSLATIONAL LIFT**—The additional lift obtained when entering forward flight, due to the increased efficiency of the rotor system.

**TRANSVERSE - FLOW EFFECT**—A condition of increased drag and decreased lift in the aft portion of the rotor disc caused by the air having a greater induced velocity and angle in the aft portion of the disc.

**TRUE ALTITUDE**—The actual height of an object above mean sea level.

**TURBOSHAFT ENGINE**—A turbine engine transmitting power through a shaft as would be found in a turbine helicopter.

**TWIST GRIP**—The power control on the end of the collective control.

**UNDERSLUNG**—A rotor hub that rotates below the top of the mast, as on semirigid rotor systems.

**UNLOADED ROTOR**—The state of a rotor when rotor force has been removed, or when the rotor is operating under a low or negative G condition.

**USEFUL LOAD**—The difference between the gross weight and the basic empty weight. It includes the flight crew, usable fuel, drainable oil, if applicable, and payload.

**VARIATION**—The angular difference between true north and magnetic north; indicated on charts by isogonic lines.

**VERTICAL VIBRATION**—A vibration in which the movement is up and down, or vertical, as in an out-of-track condition.

**VORTEX RING STATE**—A transient condition of downward flight (descending through air after just previously being accelerated downward by the rotor) during which an appreciable portion of the main rotor system is being forced to operate at angles of attack above maximum. Blade stall starts near the hub and progresses outward as the rate of descent increases.

**WEIGHT**—One of the four main forces acting on a rotorcraft. Equivalent to the actual weight of the rotorcraft. It acts downward toward the center of the earth.

**YAW**—The movement of a rotorcraft about its vertical axis.

## Appendix I:

### Gyroplane Take-off Procedures

- I. **Demonstrate your knowledge of the standard take-off procedure (and your ability to explain it to your student) by outlining the specific steps to execute take-off in the MTO Gyro in logical, step-wise fashion. In addition, include the rationale for each step and the anticipated result of each action taken.**

#### Standard Take-off Procedure in Gyroplane

**Gyro Take-off** requires coordination of two distinct, but interrelated, elements:

1. Rotor speed
2. Airspeed

Sufficient rotor speed with insufficient airspeed will put the gyroplane on the backside of the power curve (*i.e., slow air speed with a high rotor disc angle.*)

Alternatively, sufficient airspeed/ground speed (or excessive speed if the cyclic is too far forward on take-off), but insufficient rotor speed will result in failure of the aircraft to leave the ground in a timely fashion.

Sufficient rotor speed AND airspeed to achieve take-off are accomplished through a series of carefully defined and coordinated steps:

1. Perform pre-rotation to achieve sufficient rotor speed to prevent rotor blade flapping (approximately 200 RPM) with the cyclic in the full forward and centered position.
2. Initiate forward acceleration of the aircraft by releasing the brake, placing the cyclic in the fullback and centered position, and gradually applying power with the throttle.
  - *This maneuver LOADS the rotor system by putting the rotor disc in its maximum rearward angle.*
  - *This allows the rotor disc to spin up to the maximum RPM that can be reached while the aircraft is still on the ground.*
3. As the aircraft accelerates forward, the rotor generates more lift and the nose wheel becomes light at which time the pilot can sense a reduction of the aircraft's forward speed.
4. At this time, more airspeed is required. This is accomplished by moving the cyclic slightly forward. Doing so results in re-acceleration of the aircraft that can also be sensed.
5. Continue to make incremental changes to forward cyclic position in order to balance on the main wheels while increasing power. These coordinated, incremental cyclic and throttle adjustments will allow the proper increase in forward air speed and maintain the proper angle of attack for takeoff.
6. At this point, adjust the cyclic and throttle to achieve 500 feet per minute at 60 miles per hour.

## II. What are the essential differences between a soft field and a standard take-off?

### How Soft Field Take-off Differs from Standard Take-off Procedure

Taking-off from a soft field in a gyroplane differs from the standard take-off procedure primarily in the following ways:

1. The nose wheel comes off the ground sooner than with the standard take-off procedure.
2. Take-off roll is shorter.
3. Acceleration to climb speed is accomplished with the nose higher than the standard procedure and obtained is after the plane is airborne.
4. *NOTE: The angle of attack for a soft field takeoff is higher than that for standard take off.*

## III. Demonstrate your knowledge of the differences between soft field and standard take-off procedures (and your ability to explain it to your student) by outlining the specific steps of a soft field take-off that differ from a standard take-off in logical, step-wise fashion.

### Soft Field Take-off Procedure

1. Pre-rotate rotors as with a standard take-off.  
*NOTE: The greater the rotor RPM achieved with pre-rotator prior to take-off, the shorter the take-off roll distance.*
2. Instead of positioning the cyclic from the full back position to more mid-range with initial acceleration as would be done in a standard take-off, position the cyclic to hold a slightly nose-high attitude (Anticipate climbing in this nose-high attitude behind the power curve once airborne.)
3. Apply sufficient power to maintain this “nose higher than normal” attitude while rolling forward. Balance on the main wheels as the rotor RPMs increase to speed sufficient to obtain and maintain flight.
4. Once the plane is airborne, re-position the cyclic slightly more forward to level the aircraft and accelerate to climb speed by applying and maintaining sufficient power to climb.
  - a. *NOTE: Anticipate that, upon becoming airborne in the “nose higher than normal” attitude, airspeed will be about 10 MPH lower than the best climb speed, i.e., aircraft will be flying behind the power curve.*
  - b. *NOTE: Failure to level the aircraft once airborne and continuing to fly behind the power curve may result in the plane slowing down and settling back to the runway.*
  - c. *NOTE: Best angle of climb in MTO Sport Gyro is 55 MPH.*
5. Keep the aircraft heading under control during this early climb phase. Failure to do so could result in ground contact with sideways (yaw or turn/tilt) movements, thus increasing the likelihood of aircraft roll-over.
6. If, for whatever reason, take-off must be aborted, anticipate a harder landing than normal.



## Appendix II:

### Gyroplane Approaches for Landing

There are three types of approaches for landing a gyroplane.

- I. Standard Approach
- II. Reduced Power Approach (to simulate emergency landing)
- III. Vertical Descent Approach

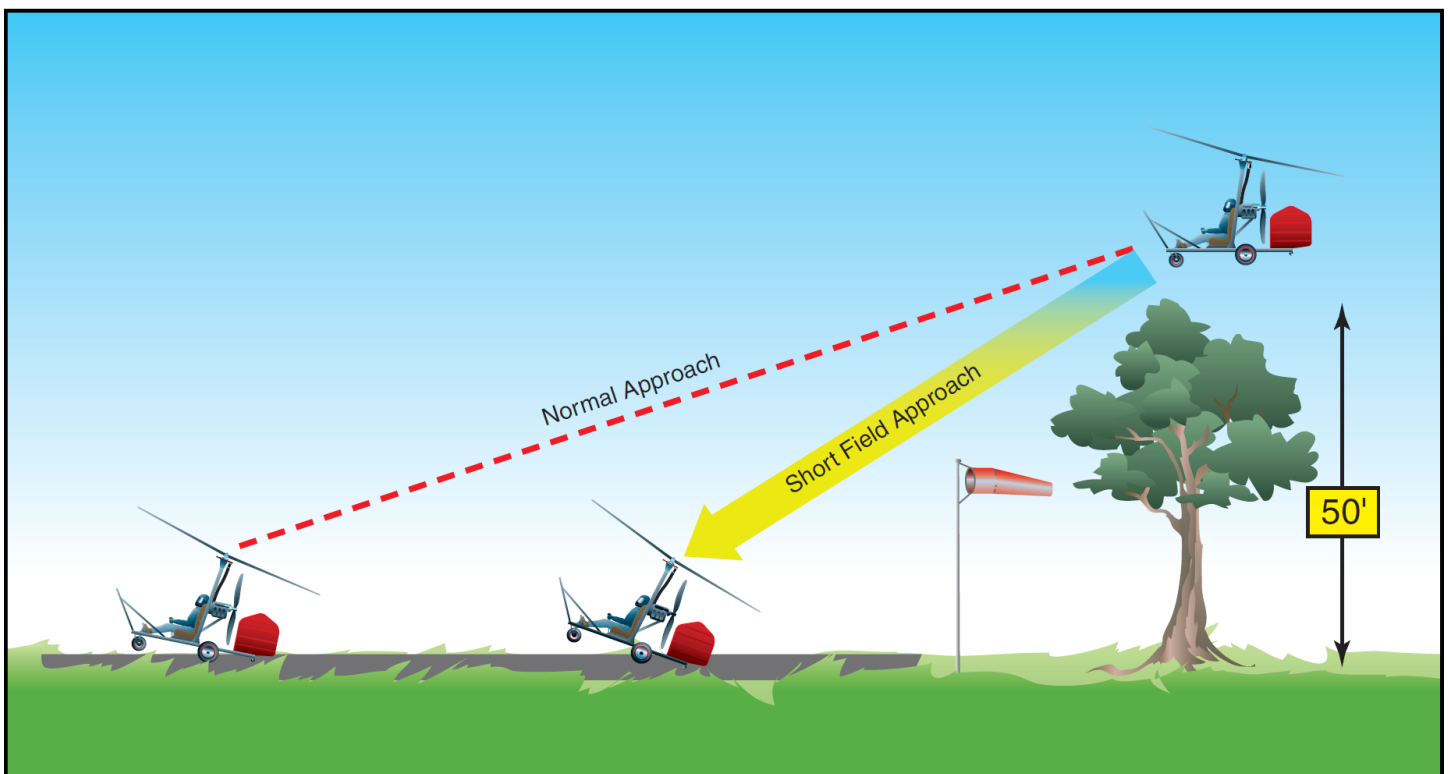
#### I. STANDARD APPROACH

- Descend from pattern altitude while maintaining the appropriate descent airspeed.
- The final approach distance from the end of the runway will vary depending on the power setting for a given approach speed
  - The use of less power results in a steeper descent
  - The use of more power results in a flatter descent

The standard approach for landing is not recommended where the runway is relatively short **and/or** has obstacles near the approach threshold. See "Vertical Descent Approach" below

#### II. REDUCED POWER DESCENT FOR SIMULATED EMERGENCY APPROACH FOR LANDING

- While it is necessary for flight instructors to dedicate a reasonable amount of time for teaching/ practicing simulated engine failures (180-degree turn to land), the majority of flight training time should be dedicated to practicing the approaches and landings that a pilot will use on a regular basis.
- This approach for landing should only be practiced with the engine running.
- Because of the steep descent, this approach should be practiced close to the end of the runway.
- Use a power setting that generates near zero thrust at the desired approach speed of the aircraft.
- In an actual engine out emergency landing, the pilot will be subjected to a totally different environment than those conditions experienced during controlled training situations, e.g. varying wind conditions, unfamiliar geographical locations and terrain and heightened emotional intensity associated with a true emergency.
- The pilot is expected to use his/her best pilot skills, judgment, and procedures during actual engine failure.



\* or manufacturer's recommendation

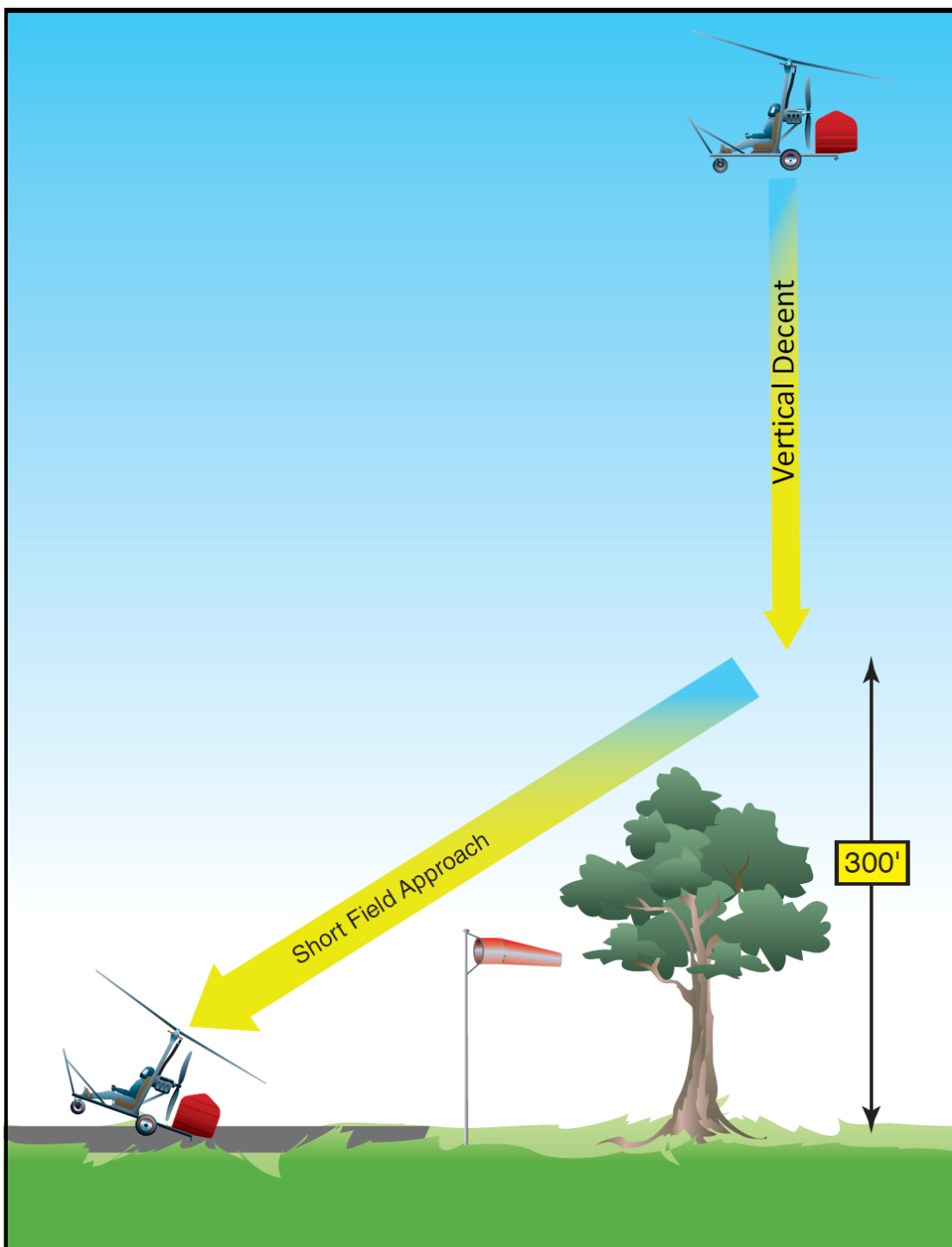
### III. VERTICAL DESCENT APPROACH

#### Benefits:

- This approach is useful when landing on a shorter runway and if there are obstacles
- This allows the pilot to better determine the best possible touchdown spot and to avoid obstacles with a greater margin of safety.
- Base-to-final pattern will be closer to the runway.

#### Procedure:

1. Begin final approach from pattern altitude closer to the threshold of the runway
2. Adjust the throttle to 3000\* RPM
3. Reduce air speed to 40 MPH\* by pulling the cyclic slightly aft
4. Maintain this approach descent configuration until reaching 300 feet AGL
5. At 300 feet AGL, gently move the cyclic forward to regain 60 MPH\* approach speed for landing
6. Use additional power, if needed.
7. Maintain aircraft alignment with the centerline of the runway using rudders for control during the completion of the landing.



NOTE: The above approaches are based on 2 place gyroplanes. Air speeds will vary depending on aircraft manufacturer's recommendations.

\* or manufacturer's recommendation